

LEARNING RESOURCE MATERIAL

ON

ANALYSIS OF STRUCTURE (CET401)

UNDER EDUSAT PROGRAMME



SCTE&VT, BHUBANESWAR ODISHA

Coordinator: Dr S. K. Nayak ,
Training Superintendent
Govt. Polytechnic, Bhubaneswar

Nodal Officer: Dr P. K. Muduli,
Sr.Lecturer (Civil).
Govt. Polytechnic, Kendrapara

CONTENTS

Chapter No.	Topic Name	Page No.	Prepared by
01	TRUSSES AND FRAMES	2-17	Dr M. R. Samal, Sr. Lecturer (Civil), GP, Bolangir
02	SLOPE AND DEFLECTION	18-71	Dr S. K. Nayak , Training Superintendent GP, Bhubaneswar
03	FIXED BEAM	72-81	Sri B. C. Sahu, Sr. Lecturer (Civil) GP, Nabarangpur
04	CONTINUOUS BEAMS – THEOREM OF THREE MOMENTS METHOD	82-91	Dr P. K. Muduli, Sr. Lecturer (Civil). GP, Kendrapara
05	MOMENT DISTRIBUTION METHOD FOR INDETERMINATE STRUCTURES	92-104	Sri N.R. Pattnaik Sr. Lecturer (Civil) GP, Balasore
06	COLUMNS AND STRUTS	105-113	Dr P. K. Mohanty, Principal ITI, Dhenkanal
07	ARCHES	114-120	Pratima Sabar Lecturer (Civil) UGMIT, Rayagada

CHAPTER-1

TRUSSES AND FRAMES

Trusses and frames- Trusses are structures or structural components consisting of axially loaded elements suitably connected/jointed by hinges or pins in contrast to frames which have moment resisting joints.

Common Types of Roof Trusses:-

The various types of roof trusses commonly used are as under:

(1) **Warren and Pratt Trusses:-**These trusses are commonly used for the flatter roofs for spans of roughly 12 to 38m. The warren truss is usually a little more satisfactory than the Pratt. The roofs may be completely flat for spans not exceeding 10 to 15m, but for longer spans, slopes for drainage purpose are purposely provided.

(2) **The Pitched Pratt and Howe Trusses:-** These trusses are the most common types and medium size trusses which have maximum economical spans of about 30m.

(3) **Fink Truss:-**This type of truss is used for steep roofs. Fink trusses are economically used for spans upto 35m. The most of the members of fink trusses are in tension. Fink trusses are further classified as French or cambered fink and fan fink.

(4) **Bow String Trusses:-** This type of truss is used for curved roofs for spans upto 30m. These are specially suited for ware houses, supper markets, garage and small industrial buildings.

(5) **Steel Arch Truss:-**This type of truss is used for spans over 30m.

Statically Determinate and Indeterminate Trusses

The trusses where all the member forces or support reactions could be found out by using the statical equations of equilibrium alone are called determinate trusses, otherwise they are statically indeterminate (redundant) having members or reaction components in excess of that can be found out by the equations of statics alone and may require deformation/compatibility equations for solution of such type of trusses..

The plane struss consists of a number of bars jointed together, such that they lie in one plane and form a frame-work which is stable against any type of loading acting in the same plane. The plane trusses can be classified as :

- i) Simple Trusses
- ii) Compound Trusses
- iii) Complex Trusses

Simple Trusses:-

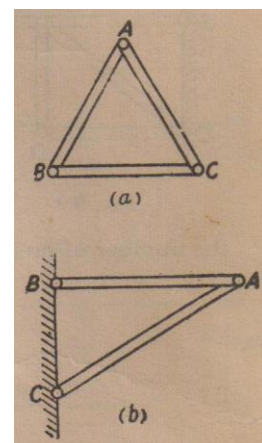

The simplest form of the truss frame-work which should be stable can be formed as follows:

- a) By connecting three bars by means of pins to form a triangle as in Fig.

(a) suitable connected to the foundations.

This will form a rigid frame which will not collapse.

- b) By taking two bars from rigid foundations and jointing them by means of a pin at the end to form a triangle as in Fig. This will form a rigid frame which will not collapse.

In any other form the frame-work will not rigid. For example, the frame-work consisting of four bars in the form of polygon ABCD, as shown in Fig. is not stable and can collapse as shown by dotted lines.

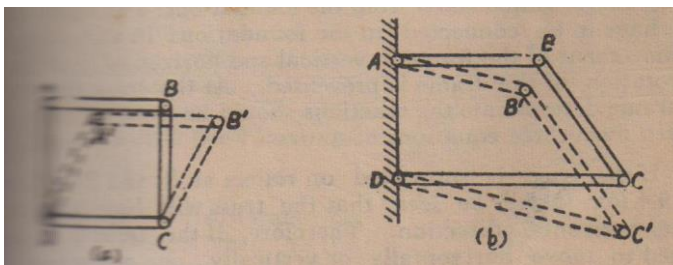

In case the frame-work consists of two bar AB and DC from the rigid foundations, their ends being connected by the third bar BC. The frame-work will collapse as shown by dotted lines in Fig.

Beginning with the rigid frame ABC by adding two bars AD and CD pinned together at D, we have rigid frame ABCD shown in Fig. The frame

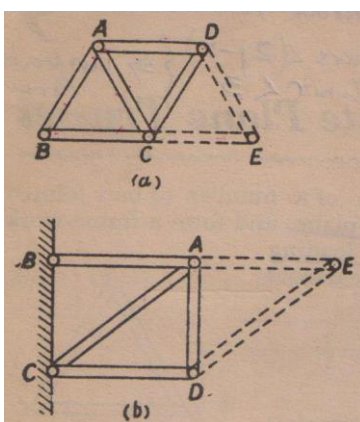

can be further extended by adding two bars which should not be in the same straight line pinned together as shown by dotted line in Fig.

There is a definite relationship between the number of bars or members m and number of joints, j in simple trusses.

In the case of the truss shown in Fig. which starts with the basic triangular frame ABC, there are three member and three joints for frame ABC and further for every joint there are two members. Leaving the basic triangle, if m is the number of members and j' is the number of joints.

In the case of the truss shown in Fig. not counting the points of attachments to the foundation as joints, there will be two members for each joint, e.i.

Connection to Foundations: The truss of Fig. will have to be connected to the foundations suitably unlike the truss in Fig. which starts from the foundation. The frame ABCED shall have to be connected to the foundations in a manner so that the movement of the frame in vertical and horizontal directions and the rotation of the frame is prevented. At the same time to make the frame determinate the reactions should be such as could be calculated from three equations of statics $\sum V=0$, $\sum H=0$ and $\sum M = 0$.

If the truss is supported on rollers at B and E as shown in Fig. it will be seen that the truss will have no constraint in the horizontal direction. Therefore, if the truss is to be constrained to move horizontally or vertically, one connection to the foundation should be a hinged one. The other connection should be such as to prevent rotation about the hinge.

The connection shown in Fig. will be adequate and will produce reactions which can be calculated, as at the hinge B, the reaction will have two components and the reaction at E will be vertical. The three unknowns can be calculated by the three equation of equilibrium.

In Fig. the truss is connected to the foundations by two hinge at B and E.

The reactions at B and E both will have two components and, therefore, there will be four unknowns and the usual three equations of equilibrium will not be sufficient to evaluate the four unknowns.

Therefore, the truss in Fig. is called externally indeterminate. Similarly

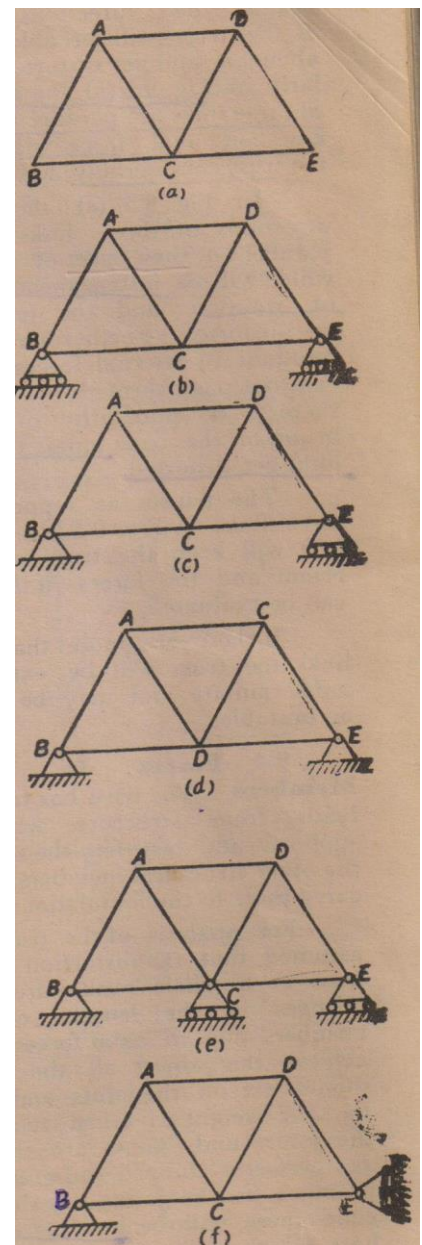

the truss in Fig. as supported will have four unknown reactions two at B, one at C and one at E and, therefore, it is externally indeterminate.

The truss in Fig. has three unknown reactions two at B and one at E but all these three pass through B, therefore, the truss will rotate about the point B and get distorted. Thus three reactions which are not parallel and which do not meet at one point are sufficient to keep the truss in equilibrium and these can be worked out from the three equations of statics $\sum V=0$, $\sum H=0$ and $\sum M=0$. If there are less than three unknown reactions the truss will not be stable. If there are more than three unknown reactions, the truss is said to be indeterminate, externally and may be stable or unstable.

The other way of supporting trusses is to connect them to the foundations by means of links hinged at the truss joints. From the above discussions it is clear that three links, the directions of which do not meet at any point or are not parallel, will keep the truss in equilibrium and the forces in these links can be worked out by three equations of statics.

In Fig. there links connect truss to the foundations but as their directions meet at B, the truss will be able to rotate about B and get distorted. Similarly in Fig. the directions of three links are parallel therefore, any horizontal force will distort the truss considerably.

In Fig. though the directions of three links are not parallel but they meet a point O which will be instantaneous centre of rotation and the truss will get distorted. Furthermore if the resultant of external forces applied does not pass through the point O, there is no possibility of equilibrium of the truss unless the three links get distorted.

The trusses as supported by three links in Fig. will keep the truss in equilibrium and the forces in the links can be evaluated.

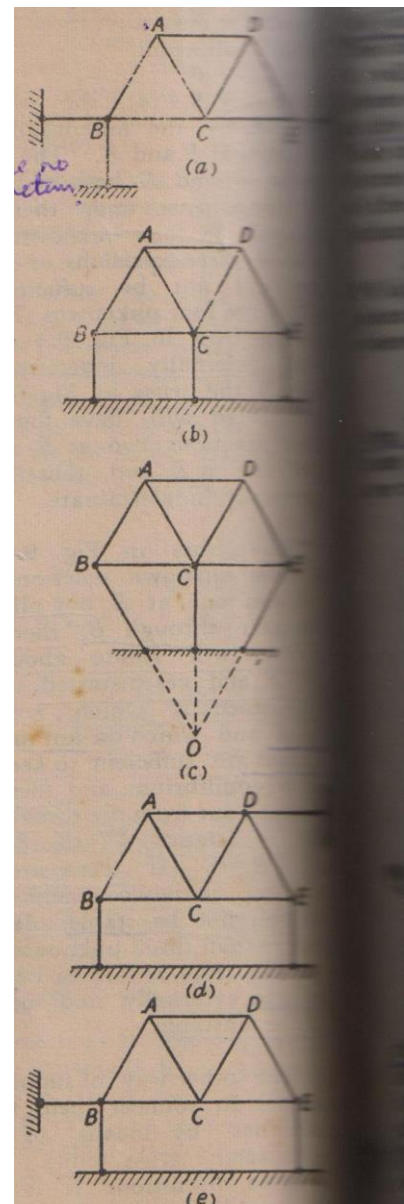

If there are more than three links the truss will be externally indeterminate and may be stable or unstable.

Forces in Truss Members: The truss has to carry loads from structure which it supports and transfers the same to the other structural members which carry these to the foundations.

For analysis of the truss it is assumed that the distortion of the truss as a whole results from the changes in the lengths of the members due to axial forces. To achieve this object all the loads should act on the joints and even the self weight is taken to act at the joints and joints are treated as perfectly hinged. In actual practice, as the joints are slightly rigid there will be bending of the bars which will cause secondary stresses. These are neglected in the first analysis. Therefore, the members will carry only axial forces, tensile or compressive.

For analysis the truss members are assumed to be weightless, meeting at frictionless joints and the external loads are applied at the joints in the plane of the truss. If a free body diagram of

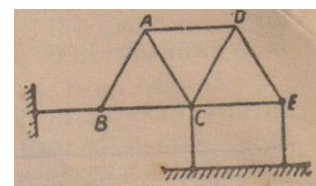

each joint is drawn, it will consist of a system of co-planer forces consisting of external forces acting at the joint and axial forces induced in the bars meeting at the joint. This system of forces will be in equilibrium. The analysis of the truss is to find the internal forces induced in the bars.

As discussed previously the rigid frame-work as shown in Fig. will satisfy the following equation between members and joints.

$$m = 2j - 3$$

Where m =number of members

j =number of joints

At each joint there will be two equations of equilibrium, therefore, for j joints there will be $2j$ equations. For externally determinate truss three reaction components which do not meet at a point are necessary for connecting to the foundations.

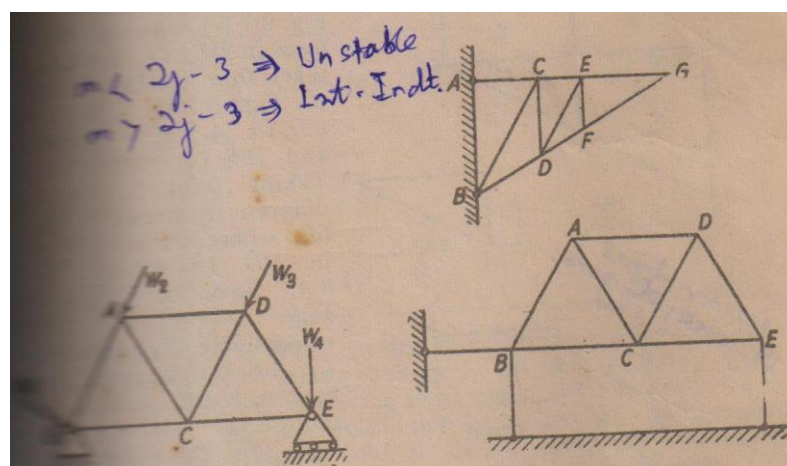

The total number of unknowns, i.e. forces in members and the three reaction components should be equal to $2j$, if the frame is to be stable and determinate. Therefore, number of members, m should be equal to $2j-3$. If the number of members is less than $2j-3$, there will be more equations than the unknown and the frame will be unstable. If the members are more than $2j-3$, the equations will not be sufficient to solve these unknowns and the frame is in the arrangement of the bras. The rigid frame formed as discussed previously will be stable and determinate.

In case of truss formed by starting with a rigid foundation as shown in Fig.9.6 (b), for a rigid truss, $m=2j$, the connection at the foundation is not counted as a joint.

At each joint there are two equations of equilibrium, therefore, for j joints there will be $2j$ equations and with these equations, forces in $2j$ members can be solved. Thus $m=2j$.

In the case of rigid frame-work connected to the foundations by three links as in Fig. if connecting links are included as members of the truss, then for j joints there are $2j$ equation and number of members necessary will be given by $m=2j$.

Analysis of Forces in Members of a Simple Truss:-The force in members of simple truss can be worked out by any of three methods:

- i) Graphical
- ii) Method of Joints
- iii) Method of Sections

(i) Method of Joint:- In this method, an imaginary section is passed around a joint a joint in the truss, completely isolating it from the remainder of the truss. The joint becomes a free body which remains in equilibrium under the forces applied to it. For the determination of the unknown can be determined at a joint with these two equations.

(ii) Method of Sections:- In this method an imaginary section is passed completely through the truss dividing it into two free bodies, and cutting the member whose force is desired and as few other members as possible. We know that the algebraic sum of the moments of all the forces applied be a free body about any point in the plane of the truss is zero. In order to determine the force in the desired member, take moments of the force about a point so that only the desired unknown force appears in the equation. To achieve this the moments are taken about a point along the line of action of one or more of the forces of the other members.

The method of sections is very useful tool for determining the force in only one member of a truss if it is not near the end of the truss.

In writing the moment equation $\sum M = 0$, the unknown force is assumed in tension i.e. pulling away from the force body. If the solution gives a positive sign, the force is tensile and if negative the force is compressive.

Graphical method of analysis

Graphic Statics:-

Determination of reactions and forces in structural works by graphical methods, is known as graphic statics. Solution of very complicated types of trusses i.e. towers can be done very easily graphically avoiding analytical methods.

1. Basic concepts of graphic statics:- The following concepts may be understood clearly before attempting the analysis of trusses by graphical methods.

i. Force:- A force is represented by a vector. A vector may be drawn parallel to the force with an arrow to represent its direction and a scaled length to represent its magnitude. The vector merely represent the centres of gravity of the loads, the structural members carry.

ii. Resultant of Forces:- Two non-parallel forces intersecting at one point, may be graphically combined into one resultant with the help of a force triangle or a force parallelogram. The magnitude of the resultant force is obtained by scaling it with the same scale as that of the forces.

The resultant of three or more forces may be obtained by selecting an arbitrary point as the starting position and successive lines for each of the forces are drawn parallel to the actual forces and scaled their proper magnitudes. The resultant of the forces is finally obtained by drawing a line from the starting point to the ending point. It may be noted that the resultant of all forces applicable to a body in equilibrium is zero and hence, the starting and closing points of polygon of forces coincide. (Fig. 15.44)

2. Bow's Notation:- The system of numbering the members load and reactions of a truss by placing a letter in each of the triangles of truss and in the space between each of the external loads and reactions, is known as Bow's notation.

Analysis of trusses by graphical method is very much eased by adopting this mode of notation. Each external force is thus designated by a pair by letters. Similarly, the internal forces in the members of the truss are designated by the pairs of letters on each side of it.

The numbering of forces is usually started from left and support and continued in clockwise direction spirally.

3. Force polygons for individual joints:- The resultant of forces meeting at a joint may be obtained by drawing a polygon of forces at that joint. Subsequent joints are taken out one by one and a force polygon is drawn for each.

4. The Maxwell diagram:- The combined diagram of the force polygons for all the joints of a truss, in which each force is represented with only one line, is called the *Maxwell diagram or Reciprocal polygon diagram*. While drawing a Maxwell diagram, the forces are considered in clockwise direction around the joints.

5.Polar diagram- It is the vector diagram of all the external forces acting on the structure represented by their arbitrary triangular components such that they have a common apex or point of resolution called pole.

In Fig. the analysis of the truss has been done by taking joint. E first and drawing the vector diagram as at Fig. the force in DE i.e. 2-4 is compressive. Taking joint D, the vector diagram is drawn in Fig. where the value of force in DE, i.e. 2-4 has been taken from the vector diagram of Fig. The member CD, i.e. 4-5 is in compression and DA i.e. 1-5 in tension. Taking joint C, the vector diagram is drawn in Fig. in CD i.e. 4-5 and CE, i.e. Fig. respectively. The member BC, i.e. 3-6 is in compression and member AC, i.e. 5-6 is in

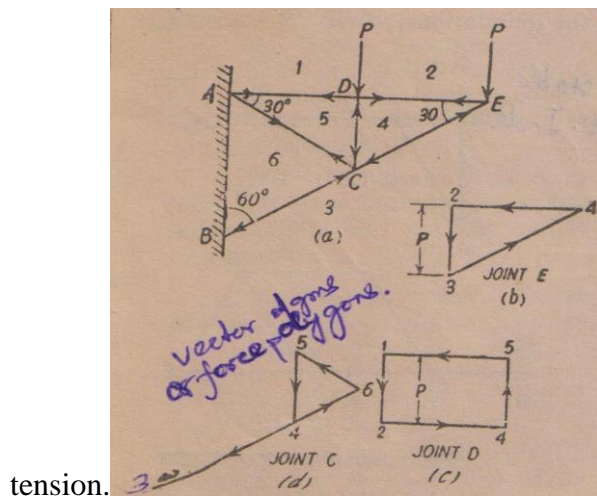

In this construction it is seen that the vectors 2-4, 4-5, 3-4 appear in two vector diagrams. To eliminate this a single vector diagram can be drawn as shown in Fig. (e) from which forces in all the members can be found out. First vectors 1-2 and 2-3 are drawn representing external loads.

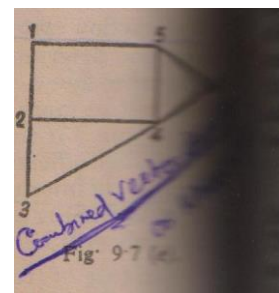

The vector diagram (2-3-4-2) represents conditions at joint E, the vector diagram (1-2-4-5-1) represents conditions at joint D, the vector diagram (5-4-3-6-5) represents conditions at joint C. To find whether the member is in compression or in tension, read the member in clockwise direction at any joint and read in the same way in the combined vector diagram, give the arrow on the member at the same joint in the directions as is read in the vector diagram. If the arrow is towards the joints, the member will be in compression if away the member will be in tension.

Analysis of frames structures:- The stresses in the various members of a framed structure may be determined by one of the following methods, discussed here under.

(A) Method of joints:-

Proceed as under;

1. Determine the support reactions.
2. Consider the equilibrium of the joint where forces in two members are only unknown.
3. For static equilibrium of the joint, apply the following two conditions.
4. Solve the above equations, to determine the unknown forces in the members.

The following solved examples will explain the working principal of the method joints.

Example - Find the forces in members BC, BG and HG for the given symmetrical pin jointed truss and loading as shown in Fig. 8.17, by graphical or any other method. The load of 10t acting at joint B is at right angles to the member AB and BC. The other loads act vertically downwards as shown in Fig. 8.17 ?

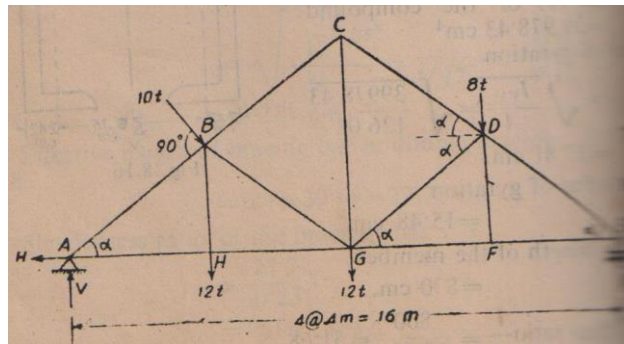

Solution:-

We shall find the forces in all the members analytically.

Let. R_1 = vertical reaction at B $\sin \alpha = \frac{3}{4}$

V = vertical component of reaction at A $\cos \alpha = \frac{4}{5}$

H = horizontal component of reaction at A

Resolving the forces vertically, we get

$$R_1 + V = 12 + 12 + 8 + 8 = 40$$

Taking moments of the forces about A, we get

$$R_1 = \frac{10 \times 5 + 12 \times 4 + 12 \times 8 + 8 \times 12}{16} = 18.125t.$$

Substituting the value of R_1 in eqn. (i) we get

$$V = 40 - 18.125 = 21.875t.$$

and $H = 10 \sin \alpha = 10 \times \frac{3}{5} = 6t.$

Joint E:

Resolving the forces vertically,

$$R_1 - F_{DE} \sin \alpha = 0 \quad \text{assuming the force } F_{DE} \text{ as compression}$$

$$F_{DE} = +18.825 \times \frac{5}{3} = 30.208t. \quad \text{(Compression)}$$

Resolving the forces horizontally,

$$F_{DE} \cos \alpha - F_{EF} = 0 \quad \text{assuming the force in } F_{EF} \text{ as tensile.}$$

$$F_{EF} = +30.208 \times \frac{4}{5} = 24.167t. \quad \text{(Tension)}$$

Or

Joint F:

Resolving the forces horizontally,

$$F_{EF} = F_{FG} = 24.167t. \quad \text{(Tension)}$$

Resolving the forces vertically,

$$F_{FD} = 0$$

Joint D:

Resolving the forces vertically,

$$-8 + F_{DF} + F_{DE} \sin \alpha - F_{DC} \sin \alpha + F_{DG} \sin \alpha = 0$$

$$-8 + 0 + 30.208x \frac{3}{5} - F_{DC}x \frac{3}{5} + F_{DG}x \frac{3}{5} = 0$$

$$-F_{DC} + F_{DG} = -16875 \quad \dots\dots\dots(i)$$

Resolving the forces horizontally,

$$-F_{DG} \cos \alpha + F_{DE} \cos \alpha - F_{DC} \cos \alpha = 0$$

$$-F_{DC} + 30.208 - F_{DG} = 0$$

$$-F_{DC} - F_{DG} = -30.208 \quad \dots\dots\dots(ii)$$

Solving eqns. (i) and (ii) we get

$$F_{DC} = 23.54t. \quad \text{(Compression)}$$

and $F_{DG} = 6.667t. \quad \text{(Compression)}$

Joint C:

Resolving the forces vertically,

$$F_{CD} \sin \alpha + F_{CB} \sin \alpha - F_{CG} = 0$$

Resolving the forces horizontally,

$$F_{CD} \cos \alpha = F_{CB} \cos \alpha$$

Or $F_{CD} = F_{CB} = 23.54t \quad \text{(Compression)}$

Substituting the values of F_{CB} in eqn. (i)

$$2 \times 23.54x \frac{3}{5} - F_{CG} = 0$$

$$F_{CG} = 28.25t$$

Or **Joint G:**

Resolving the forces vertically,

$$F_{CG} - 12 - F_{GB} \sin \alpha - F_{GD} \sin \alpha = 0$$

$$28.25 - 12 - F_{GB}x \frac{3}{5} - 6.667x \frac{3}{5} = 0$$

Or $F_{GB} = +12.25x \frac{5}{3} = 20.42t \quad \text{(Compression)}$

Resolving the forces horizontally,

$$-F_{GH} + F_{GB} \cos \alpha + F_{GF} - F_{GD} \cos \alpha = 0$$

$$-F_{GH} + 20.42x \frac{4}{5} + 24.167 - 6.667x \frac{4}{5} = 0$$

$$F_{GH} + 35.17 = 0$$

Or $F_{GH} = 35.17t.$ (Tension)

Joint H:

Resolving the forces vertically,

$$F_{HB}=12t.$$

Resolving the forces horizontally,

$$F_{HA}=F_{HG}=35.17t.$$

Joint A:

Resolving the forces vertically,

$$F_{AB} \sin \alpha - V = 0$$

$$F_{AB} = \frac{V}{\sin \alpha} = 21.875x \frac{5}{3} = 36.46t$$
 (Compression)

Resolving the forces horizontally,

$$F_{AB} \cos \alpha + H - F_{AH} = 0$$

$$36.46 x \frac{4}{5} + H - 35.17 = 0$$

Or $29.17+6-35.17=0$ O.K.

{	Member	Force	Tension / Compression
	BC	33.54t	Compression
	BG	20.42t	Compression
	HG	35.17t	Tension

Example. 8.11 Construct a stress diagram for the truss shown in Fig. 8.18 and determine the stresses in all the members of this truss.

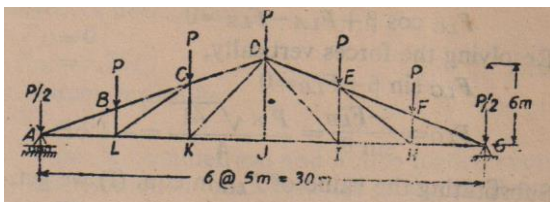

Solution: We will solve this problem by the method of joints $\sin \alpha = \frac{2}{\sqrt{29}}$

Let $\angle BAL = \alpha$; $\angle CLK = \beta$ and $\angle DKJ = Y$

Now $R_1 = R_2 = \frac{6P}{3} = 3P.$ $\cos \alpha = \frac{5}{\sqrt{29}}$

Joint A:

Assume that the member AB is in compression and member $\sin \beta = \frac{4}{\sqrt{41}}$

AL is in tension

Resolving the forces vertically,

$$\frac{P}{2} + F_{AB} \sin \alpha - R_1 = 0$$

$$\text{Or } F_{AB} \sin \alpha = 3P - \frac{P}{2} = \frac{5}{2}P$$

$$\text{Or } F_{AB} = \frac{5/2P}{\sin \alpha} = \frac{2.5P\sqrt{29}}{2} = 6.37P$$

Resolving the forces horizontally,

$$F_{AB} \cos \alpha - F_{AL} = 0$$

$$\text{Or } F_{AL} = F_{AB} \cos \alpha = \frac{2.5P\sqrt{29}}{2} \times \frac{5}{\sqrt{29}} = 6.25P$$

$$\cos \beta = \frac{4}{\sqrt{41}}$$

$$\sin \gamma = \frac{6}{\sqrt{61}}$$

$$\cos \gamma = \frac{5}{\sqrt{61}}$$

(Compression)

(Tensile)

Joint B:

Assume the forces in members BC and BL as compressive.

Resolving the forces horizontally,

$$F_{BC} \cos \alpha - F_{AB} \cos \alpha = 0$$

$$\text{Or } F_{BC} = F_{AB} = 6.73P$$

(Compression)

Substituting the value of F_{BC} and F_{AB} in Eqn. (i) $F_{BL}=P$ (Compression)

Joint L:

Assume the force in member LK to be tensile and that in LC to be compressive.

Resolving the forces horizontally,

$$F_{LC} \cos \beta + F_{LA} - F_{LK} = 0$$

Joint G:-

Assumed the forces in the members CD and CK compression.

Resolving the forces horizontally,

$$F_{BC} \cos \alpha - F_{CL} \cos \beta - F_{CD} \cos \alpha = 0$$

$$\frac{2.5P\sqrt{29}}{2} \times \frac{5}{\sqrt{29}} - \frac{P\sqrt{41}}{4} \times \frac{5}{\sqrt{41}} - F_{CD} \times \frac{5}{\sqrt{29}} = 0$$

$$6.25P - 1.25P - F_{CD} \times \frac{5}{\sqrt{29}} = 0$$

$$\text{Or } F_{CD} = \frac{5P\sqrt{29}}{5} = 5.38P$$

(Compression)

Resolving the forces vertically, we get

$$F_{CK} + F_{BC} \sin \alpha - F_{CL} \sin \beta - 2 - F_{CD} \sin \alpha = 0$$

$$F_{BK} = P + \frac{5P\sqrt{29}}{5} \times \frac{2}{\sqrt{29}} + \frac{Px\sqrt{41}}{4} \times \frac{4}{\sqrt{41}} - \frac{25P\sqrt{29}}{2} \times \frac{2}{\sqrt{29}}$$

Or $F_{CK} = P + 2P + P - 2.5P = 1.5P$ (Compression)

Joint K:

Assume the forces in the members KD and KJ to be tensile.

Resolving the forces horizontally,

$$F_{KJ} + F_{KD} \cos \gamma - F_{KL} = 0 \quad \dots\dots\dots(i)$$

Resolving the forces vertically,

$$F_{KC} - F_{KD} \sin \gamma = 0 \quad \dots\dots\dots(ii)$$

Or $F_{KD} = 1.5P \times \frac{\sqrt{61}}{6} = 1.25P$ (Tensile)

Substituting the value of F_{KD} in eqn. (i)

$$F_{KJ} + 1.95P \times \frac{5}{\sqrt{61}} - 5P = 0$$

$$F_{KJ} = 5P - 1.25 = 3.75P$$

Joint J:-

Resolving the forces horizontally,

$$F_{JK} - F_{JI} = 0$$

Or $F_{JI} = F_{JK} = 3.75P$ (Tensile)

Resolving the forces vertically,

$$F_{JD} = 0$$

Because, the truss is symmetrical and is also loaded symmetrically, the forces in the symmetrical members will be equal. Results are tabulated here under:

Sl. No.	Members	Nature	
		Comp.	Tension
1.	AB, GF	6.73P	-
2.	BC, FE	6.73P	-
3.	CD, ED	5.38P	-
4.	AL, GH	-	6.25P
5.	LK, HI	-	5.0P
6.	KJ, IJ	-	3.75P
7.	BL, FJ	P	-
8.	CK, EI	1.5P	-
9.	DJ	ZERO	ZERO
10.	CL, EH	-	.0 P
11.	DK, DI	-	1.95P

(B) Method of Sections:

Proceed as under:

1. Determine the support reactions.
2. Divide the frame by a section line in two portions such that the section line does not cut more than two unknown concurrent members.
3. Consider the static equilibrium of the joint and apply the following two conditions:

$$\Sigma V = 0 \text{ and } \Sigma H = 0$$

In case, the members of the frame cut by sections line are not concurrent, the conditions of static equilibrium are:

$$\Sigma H = 0, \Sigma V = 0, \Sigma M = 0$$

The section line may be passed to cut not more than three unknown members.

The point about which moments of the forces are taken, should be selected such that maximum number of members cut by the section line, meet there.

4. After determining the forces in the members cut by the section line, other suitable section line may be passed cutting another set of members whose forces are unknown.

Advantages: The advantages of the method sections over other methods is that forces in members particularly those away from the supports can be determined quickly by passing a section line cutting those members.

The following solved examples will explain the working principle of the method of sections.

Example 8.12. Find the forces in members BC, BG and HG for the given symmetrical pin jointed truss and loading shown in Fig. 8.19 by graphical or any other method. The load of 10t acting at joint F is at right angles to the member AB and BC. The other loads act vertically downward as shown in Fig. 8.19.

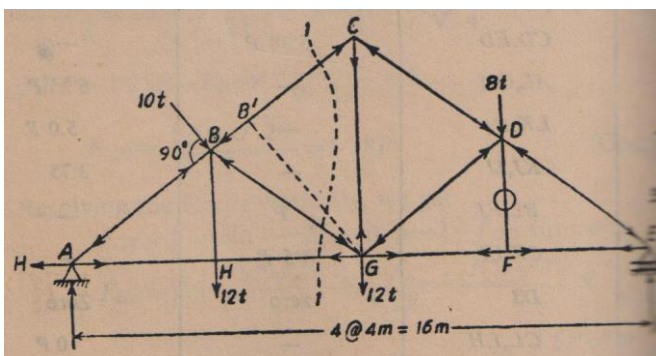

Solution:

As the forces are required only in three members, it is preferable to adopt the method of sections.

Let $\angle CAG = \alpha$

The vertical reaction at E $\sin \alpha = \frac{3}{5}$

$$R_1 = \frac{10 \times 5 + 12 \times 4 + 12 \times 8 + 8 \times 12}{16} \quad \sin \alpha = \frac{4}{5}$$

$$= 18.125t.$$

Pass a section 1-1 to cut the members BC, BG and HG as shown in the figure.

Remove the left portion of the truss.

Let Force F_{BC} be compression

F_{BG} be compression

F_{BH} be tension

Taking moments of all the external forces about G,

$$F_{BC} \times 8 \sin \alpha + 8 \times 4 = 18.125 \times 8$$

$$\text{Or } F_{BC} = \frac{18.125 \times 8 - 32}{\sin \alpha} = \frac{14.125 \times 5}{3} = \frac{70.625}{3}$$

$$\text{Or } F_{BC} = 23.54t \quad (\text{Compression})$$

Taking moments of all the external forces about B,

$$F_{HG} \times 3 + 12 \times 4 + 8 \times 8 = 18.125 \times 12$$

$$3F_{HG} + 48 + 64 = 217.500$$

$$3F_{GH} = 217.5 - 111 = 106.50$$

$$F_{HG} = 35.17 t. \quad (\text{Tension})$$

Taking moments of all the external forces about A,

$$F_{BG} \times 8 \sin \alpha + 12 \times 8 + 8 \times 12 = 18.125 \times 16$$

$$F_{BG} \sin \alpha = 36.25 - 12 - 12 = 12.25$$

$$F_{BG} = \frac{12.25 \times 5}{3} = 20.42t. \quad (\text{Compression})$$

Results:

Member	Force	Nature
BC	23.54t	Comp.
HG	35.17t	Tension
BG	20.42t	Comp.

Important uses of Trusses- Trusses are used to bridge over long spans where the use of beams or girders is generally uneconomical. They are used in the construction of bridges, warehouses or factory sheds or industrial as well as residential buildings.

CHAPTER-2

SLOPE AND DEFLECTION OF BEAMS

Introduction

When a beam or for that matter any part of a structure is subjected to the action of applied loads, it undergoes deformation due to which the axis of the member is deflected from its original position. The deflections also occur due to temperature variations and lack-of-fit of members. Accurate values for these deflections are sought in many practical cases. The deflections of structures are important for ensuring that the designed structure is not excessively flexible. The large deformations in the structures can cause damage or cracking of non-structural elements. The computation of deflections in structures is also required for solving the statically indeterminate structures.

The deflection of beam depends on four general factors:

1. Stiffness of the material that the beam is made of,
2. Dimension of the beam,
3. Applied loads, and
4. Support conditions

Elastic curve

The curve that is formed by plotting the position of the neutral axis of the beam under loading along the longitudinal axis is known as the *elastic curve*. The curve into which the axis of the beam is transformed under the given loading is called the *elastic curve*. The nature of the elastic curve depends on the support conditions of the beam and the nature and type of loadings. The slope at a given point may be clockwise or anticlockwise measured from the original axis of the beam. Figure 1 shows the elastic curves for cantilever and simply supported beams. Sagging or positive bending moment produces an elastic curve with curvature of concave upward whereas a hogging or negative bending moment gives rise to an elastic curve with curvature of concave downward.

Deflection

The vertical displacement of a point on elastic curve of a beam with respect to the original position of the point on the longitudinal axis of the beam is called the *deflection*.

Slope

The angular displacement or rotation of the tangent drawn at a point on the elastic curve of a beam with respect to the longitudinal axis of the original beam without loading is known as the *slope* at a given point.

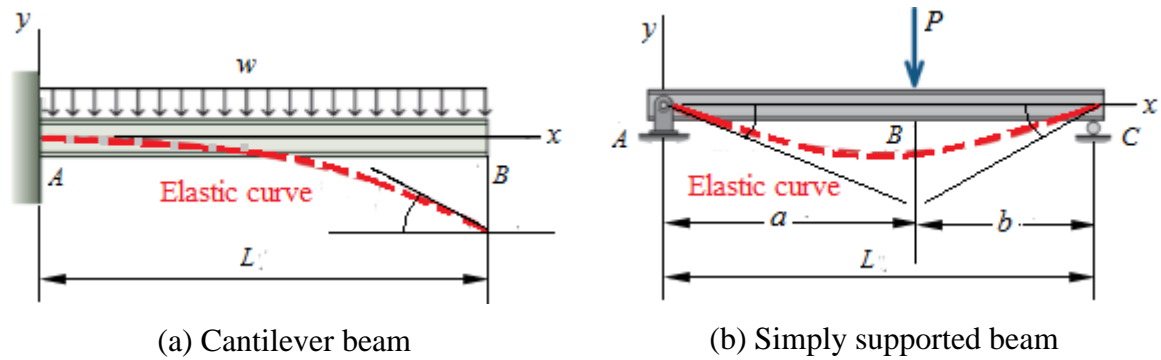

Figure 1

Importance of slope and deflection

Accurate values for these beam deflections are sought in many practical cases. The deflection of a beam must be limited in order to: (a) provide integrity and stability of structure or machine, (b) minimize or prevent brittle-finish materials from cracking. The computation of deflections at specific points in structures is also required for analyzing a statically indeterminate structures.

Equation of elastic curve

The following assumptions are made to derive the equation of the elastic curve of a beam.

Assumptions:

1. The deflection is very small compared to the length of the beam.
2. The slope at any point is very small.
3. The beam deflection due to shearing stresses is negligible, i.e., plane sections remain plane after bending.
4. The values of E and I remain constant along the beam. If they are constant and can be expressed as functions of x , then the solution using the equation of elastic curve is possible.

Let us consider an elemental length $PQ = ds$ of the elastic curve of a beam under loading as shown in the Figure 1. The tangents drawn at the points P and Q make angles θ and $\theta + d\theta$ with x -axis. Let the coordinates of P and Q be (x, y) and $(x + dx, y + dy)$ respectively. The normals at P and Q meet at C . C denote the centre of curvature and ρ the radius of curvature of the part of the elastic curve between P and Q .

From the geometry of the curve, it is obvious that $ds = \rho d\theta$

or
$$\rho = \frac{ds}{d\theta}$$

and $\frac{dy}{dx} = \tan \theta$, $\frac{dy}{ds} = \sin \theta$, and $\frac{dx}{ds} = \cos \theta$

$$\rho = \frac{ds}{d\theta} = \frac{ds}{dx} \frac{dx}{d\theta} = \frac{\frac{ds}{dx}}{\frac{d\theta}{dx}}$$

$$\rho = \frac{\sec \theta}{\frac{d\theta}{dx}} \quad (1)$$

Further, $\tan \theta = \frac{dy}{dx}$

Differentiating with respect to x , one can get

$$\begin{aligned} \text{Asaa} \quad \sec^2 \theta \frac{d\theta}{dx} &= \frac{d^2 y}{dx^2} \\ \frac{d\theta}{dx} &= \frac{\frac{d^2 y}{dx^2}}{\sec^2 \theta} \end{aligned} \quad (2)$$

Substituting the value of $\frac{d\theta}{dx}$ in Eq.(1), one gets

$$\begin{aligned} \rho &= \frac{\sec^3 \theta}{\frac{d^2 y}{dx^2}} \\ \frac{1}{\rho} &= \frac{\frac{d^2 y}{dx^2}}{\sec^3 \theta} = \frac{\frac{d^2 y}{dx^2}}{(\sec^2 \theta)^{3/2}} = \frac{\frac{dy}{dx}}{(1 + \tan^2 \theta)^{3/2}} \\ \frac{1}{\rho} &= \frac{\frac{d^2 y}{dx^2}}{\left\{ 1 + \left(\frac{dy}{dx} \right)^2 \right\}^{3/2}} \end{aligned}$$

For real life actual, the slope dy/dx is very small and its square is even smaller and hence the term $\left(\frac{dy}{dx} \right)^2$ can be neglected as compared to unit. The above expression thus becomes

$$\frac{1}{\rho} = \frac{d^2 y}{dx^2} \quad (3)$$

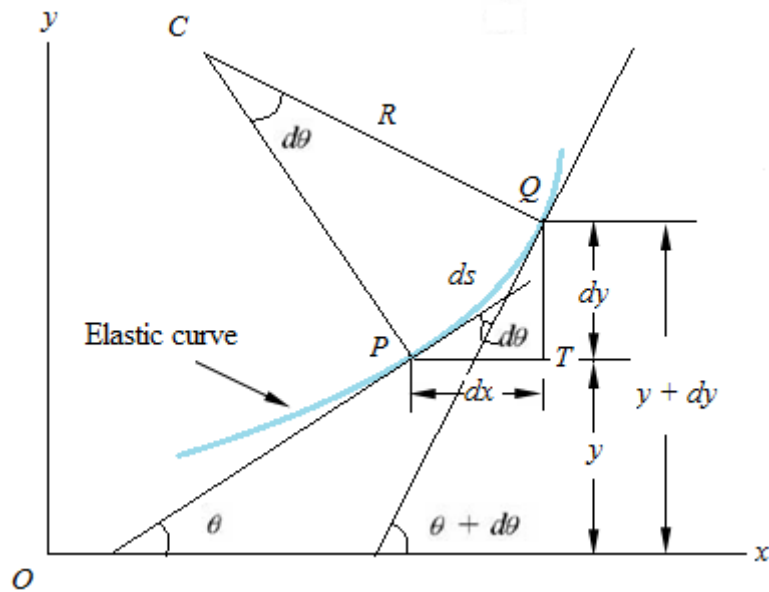

Figure 2

From theory of pure bending, it is known that

$$\frac{M}{I} = \frac{E}{\rho}$$

$$\frac{1}{\rho} = \frac{M}{EI} \quad (4)$$

From Eq. (3) and (4) we get

$$EI \frac{d^2 y}{dx^2} = M \quad (5)$$

Equation (5) is the governing equation of deflection of beam, also known as equation of elastic curve.

Boundary condition

The equation of elastic curve or the governing equation for deflection of the beam is a second order differential equation; hence we need to know two boundary conditions to find out two constants of integration for complete solution of the problem. The boundary conditions generally come from the support conditions, where either the slope or the deflection is known. Sometimes, due to symmetry of the beam, as in the case of a simply supported beam with point load at the centre of the beam or uniformly distributed load throughout the beam, an intermediate point representing the point of symmetry may give a boundary condition.

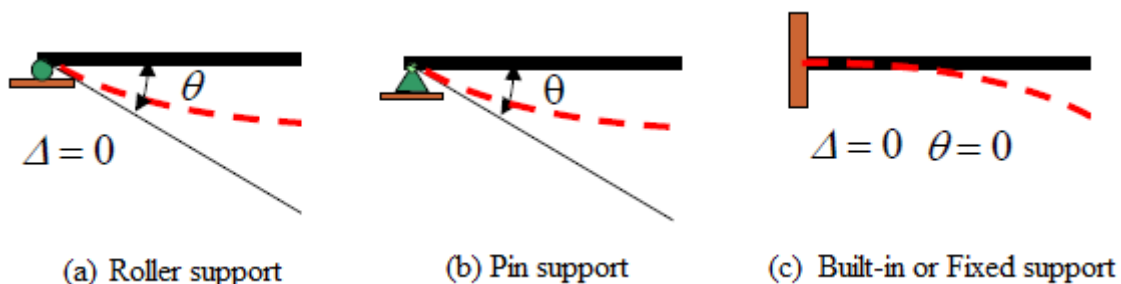

Figure 3

General procedure for computing deflection by integration

1. Select the interval or intervals of the beam to be used and place a set of coordinate axis on the beam with the origin at one end of an interval and then indicate the range of values of x in each interval.
2. List the variable boundary and continuity or matching conditions for each interval.
3. Express the bending moment M as a function of x for each interval selected and equate it to $EI(d^2y/dx^2)$.
4. Solve the differential equation from step 3 and evaluate all constants of integration. Calculate slope (dy/dx) and deflection (y) at the specific points.

Numerical Problems

Problem 1.

Derive the equation of elastic curve and find the slope and deflection at the free end of the cantilever beam shown in the Figure 4.

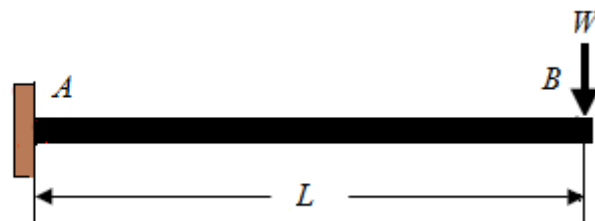

Figure 4

Solution.

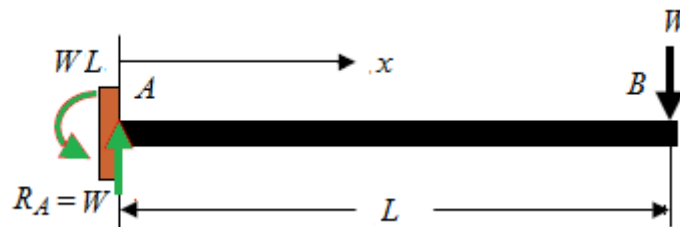

Figure 5

Determine the support reactions

Sum of the vertical forces, $\sum V = 0$, $R_A = W$

Sum of the vertical forces, $\sum M_A = 0$, $M_A = WL$

Taking moment about any section between A and B over the entire length of the cantilever, we have

$$M(x) = -WL + Wx$$

The equation of the elastic curve may be written as

$$EI \frac{d^2 y}{dx^2} = -WL + Wx$$

Integrating with respect to x , we get

$$EI\theta = EI \frac{dy}{dx} = -WLx + \frac{Wx^2}{2} + C_1 \quad (6)$$

Integrating again with respect to x , we get

$$EIy = -\frac{WLx^2}{2} + \frac{Wx^3}{6} + C_1x + C_2 \quad (7)$$

The constants integration C_1 and C_2 may be determined from the boundary conditions.

$$x = 0, \theta = 0 \text{ and } x = 0, y = 0$$

Substituting $x = 0, \theta = 0$ in Eq. (6), we get $C_1 = 0$

Substituting $x = 0, y = 0$ in Eq. (7), we get $C_2 = 0$

Substituting the values of $C_1 = 0$ and $C_2 = 0$ in Eq. (6) and Eq. (7), we get

$$\text{General equation for slope} \quad EI\theta = EI \frac{dy}{dx} = -WLx + \frac{Wx^2}{2} \quad (8)$$

$$\text{General equation for deflection} \quad EIy = -\frac{WLx^2}{2} + \frac{Wx^3}{6} \quad (9)$$

$$\text{Slope at free end } (x = L) \quad EI\theta_B = -WL^2 + \frac{WL^2}{2}$$

$$\theta_B = -\frac{WL^2}{2EI}$$

$$\text{Slope at free end } (x = L) \quad EIy_B = -\frac{WL^3}{2} + \frac{WL^3}{6}$$

$$y_B = -\frac{WL^3}{3EI}$$

Problem 2.

A cantilever beam of length L carries a uniformly distributed load of w per unit length over its entire length. Determine the slope and deflection at the free end of the beam.

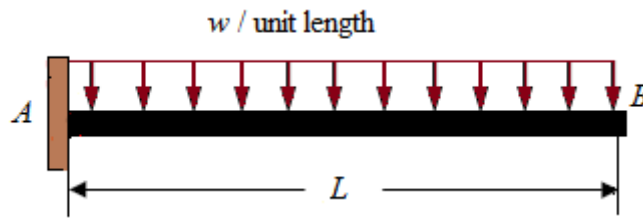

Figure 6

Solution.

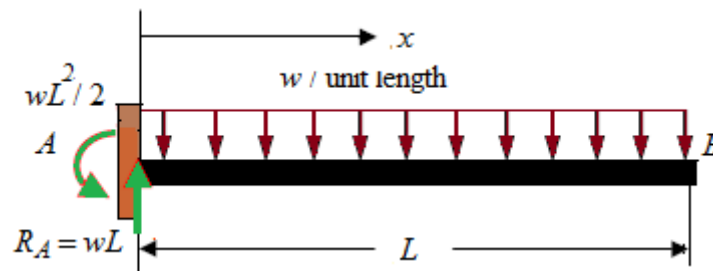

Figure 7

Determine the support reactions

Sum of the vertical forces, $\sum V = 0$, $R_A = wL$

Sum of the vertical forces, $\sum M_A = 0$, $M_A = -\frac{wL^2}{2}$

Taking moment about any section between A and B over the entire length of the cantilever, we have

$$M(x) = -\frac{wL^2}{2} - \frac{wx^2}{2} + wLx$$

The equation of the elastic curve may be written as

$$EI \frac{d^2 y}{dx^2} = -\frac{wL^2}{2} - \frac{wx^2}{2} + wLx$$

Integrating with respect to x , we get

$$EI\theta = EI \frac{dy}{dx} = -\frac{wL^2 x}{2} - \frac{wx^3}{6} + \frac{wLx^2}{2} + C_1 \quad (10)$$

Integrating again with respect to x , we get

$$EIy = -\frac{wL^2 x^2}{4} - \frac{wx^4}{24} + \frac{wLx^3}{6} + C_1 x + C_2 \quad (11)$$

The constants integration C_1 and C_2 may be determined from the boundary conditions.

$$x = 0, \theta = 0 \text{ and } x = 0, y = 0$$

The constants integration C_1 and C_2 may be determined from the boundary conditions.

$$x = 0, \theta = 0 \text{ and } x = 0, y = 0$$

Substituting $x = 0, \theta = 0$ in Eq. (), we get $C_1 = 0$

Substituting $x = 0, y = 0$ in Eq. (), we get $C_2 = 0$

Substituting the values of $C_1 = 0$ and $C_2 = 0$ in Eq. () and Eq. (), we get

General equation for slope $EI\theta = EI \frac{dy}{dx} = -\frac{wL^2x}{2} - \frac{wx^3}{6} + \frac{wLx^2}{2}$ (12)

General equation for deflection $EIy = -\frac{wL^2x^2}{4} - \frac{wx^4}{24} + \frac{wLx^3}{6}$ (13)

Slope at free end ($x = L$) $EI\theta_B = -\frac{wL^3}{2} - \frac{wL^3}{6} + \frac{wL^3}{2}$

$$\theta_B = -\frac{WL^3}{6EI}$$

Slope at free end ($x = L$) $EIy_B = -\frac{wL^4}{4} - \frac{wL^4}{24} + \frac{wL^4}{6}$

$$y_B = -\frac{WL^3}{8EI}$$

Problem 3.

Determine the slope at the end supports and deflection at centre of a prismatic simply supported beam of length L carrying a point of W at the mid span.

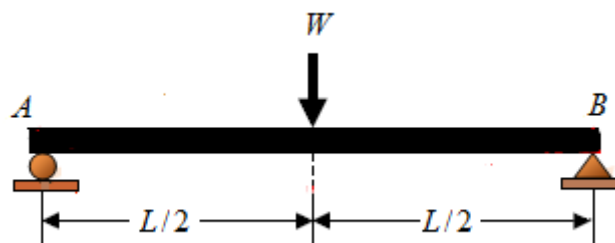

Figure 8

Solution.

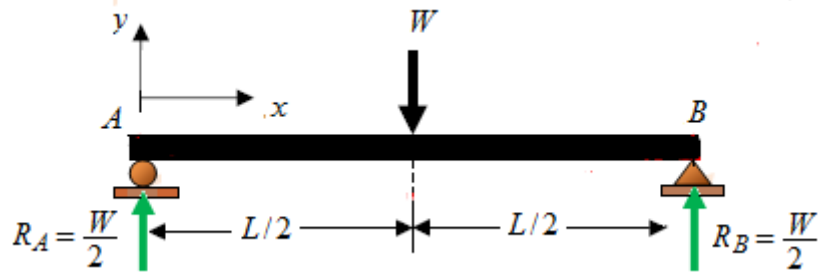

Figure 9

The beam is symmetrical, so the reactions at both ends are $\frac{W}{2}$, The bending moment equation will change beyond the centre position but because the bending will be symmetrical on each side of the centre we need to only to solve for the left hand side.

Taking moment about any section between the left hand support A and the centre of the beam, we have

$$M(x) = -\frac{W}{2}x$$

The equation of the elastic curve may be written as

$$EI \frac{d^2y}{dx^2} = -\frac{Wx}{2}$$

Integrating with respect to x , we get

$$EI\theta = EI \frac{dy}{dx} = -\frac{Wx^2}{4} + C_1 \quad (14)$$

Integrating again with respect to x , we get

$$EIy = -\frac{Wx^3}{12} + C_1x + C_2 \quad (15)$$

The constants integration C_1 and C_2 may be determined from the boundary conditions.

At A $x = 0, y = 0$ (No deflection at roller supported or hinged ends)

At C $x = \frac{L}{2}, \theta = 0$ (Tangent to the elastic curve is horizontal at the centre)

Substituting $x = \frac{L}{2}, \theta = 0$ in Eq. (14), we get $C_1 = \frac{WL^2}{16}$

Substituting $x = 0, y = 0$ in Eq. (15), we get $C_2 = 0$

Substituting the values of $C_1 = \frac{WL^2}{16}$ and $C_2 = 0$ in Eq. (14) and Eq. (15), we get

General equation for slope $EI\theta = EI \frac{dy}{dx} = -\frac{Wx^2}{4} + \frac{WL^2}{16}$ (16)

General equation for deflection $EIy = -\frac{Wx^3}{12} + \frac{WL^2x}{16}$ (17)

Slope at end A ($x = 0$) $EI\theta_A = -\frac{W(0)^2}{4} + \frac{WL^2}{16}$

$$\theta_A = \frac{WL^2}{16EI}$$

Deflection at the centre ($x = \frac{L}{2}$) $EIy_c = -\frac{W}{12}\left(\frac{L}{2}\right)^3 + \frac{WL^2}{16}\left(\frac{L}{2}\right)$

$$EIy_c = -\frac{WL^3}{96} + \frac{WL^3}{32}$$

$$y_c = -\frac{WL^3}{48EI}$$

Problem 4.

Determine the slope at the end supports and deflection at the centre of a prismatic simply supported beam shown in the Figure 10 carrying uniformly distributed load of w per unit length over the entire span of the beam.

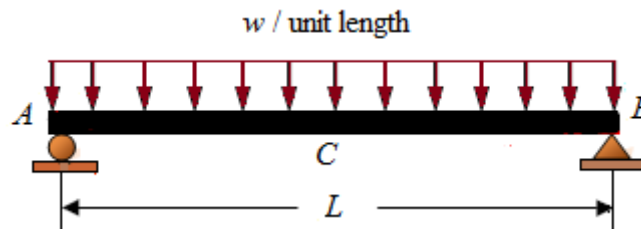

Figure 10

Solution.

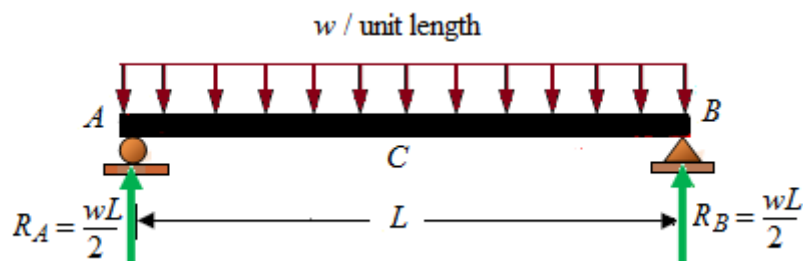

Figure 11

The beam is symmetrical, so the reactions at both ends are $\frac{wL}{2}$, The bending moment equation will change beyond the centre position but because the bending will be symmetrical on each side of the centre we need to only solve for the left hand side.

Taking moment about any section between A and B over the entire length of the cantilever, we have

$$M(x) = \frac{wLx}{2} - \frac{wx^2}{2}$$

The equation of the elastic curve may be written as

$$EI \frac{d^2 y}{dx^2} = \frac{wLx}{2} - \frac{wx^2}{2}$$

Integrating with respect to x , we get

$$EI\theta = EI \frac{dy}{dx} = \frac{wLx^2}{4} - \frac{wx^3}{6} + C_1 \quad (18)$$

Integrating again with respect to x , we get

$$EIy = \frac{wLx^3}{12} - \frac{wx^4}{24} + C_1x + C_2 \quad (19)$$

The constants integration C_1 and C_2 may be determined from the boundary conditions.

At A $x = 0, y = 0$ (No deflection at roller supported or hinged ends)

At C $x = \frac{L}{2}, \theta = 0$ (Tangent to the elastic curve is horizontal at the centre)

Substituting $x = \frac{L}{2}, \theta = 0$ in Eq. (18), we get

$$EI(0) = \frac{wL}{4} \left(\frac{L}{2}\right)^2 - \frac{w}{6} \left(\frac{L}{2}\right)^3 + C_1$$

$$C_1 = -\frac{wL^3}{16} + \frac{wL^3}{48}$$

$$C_1 = -\frac{wL^3}{24}$$

Substituting $x = 0, y = 0$ in Eq. (19), we get $C_2 = 0$

Substituting the values of $C_1 = -\frac{wL^3}{24}$ and $C_2 = 0$ in Eq. (18) and Eq. (19), we get

General equation for slope $EI\theta = EI \frac{dy}{dx} = \frac{wLx^2}{4} - \frac{wx^3}{6} - \frac{wL^3}{24}$ (20)

General equation for deflection $EIy = \frac{wLx^3}{12} - \frac{wx^4}{24} - \frac{wL^3}{24}x$ (21)

Slope at end A ($x = 0$) $EI\theta_A = \frac{wL}{4}(0)^2 - \frac{w}{6}(0)^3 - \frac{wL^3}{24}$

$$\theta_A = -\frac{wL^3}{24EI}$$

Deflection at the centre ($x = \frac{L}{2}$) $EIy_C = \frac{wL}{12}\left(\frac{L}{2}\right)^3 - \frac{w}{24}\left(\frac{L}{2}\right)^4 - \frac{wL^3}{24}\left(\frac{L}{2}\right)$

$$EIy_C = \frac{wL^4}{96} - \frac{wL^4}{384} - \frac{wL^4}{48}$$

$$y_C = -\frac{wL^4}{384EI}$$

Problem 5.

Determine the slope and deflection of the prismatic simply supported beam under the point load.

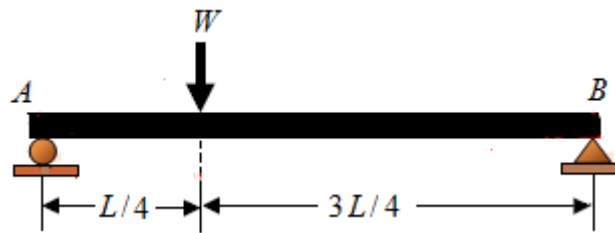

Figure 12

Solution.

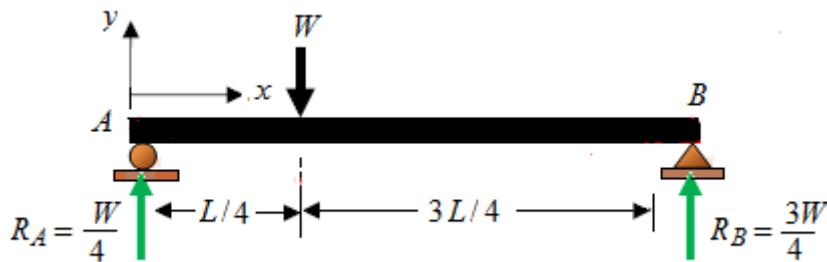

Figure 13

Determine the support reactions

Sum of the vertical forces, $\sum V = 0,$

$$R_A + R_B = W$$

Sum of the vertical forces, $\sum M_A = 0,$

$$R_A \times L = W \times \frac{3L}{4}$$

$$R_A = \frac{3WL}{4}$$

Bending moment over the portion AC and CB of the beam may be expressed by two different functions and hence the equations for elastic curves.

For portion A to C ($x < \frac{L}{4}$)

Taking moment about any section between A and C , we have

$$M_1(x) = \frac{3Wx}{4}$$

The equation of the elastic curve may be written as

$$EI \frac{d^2 y_1}{dx^2} = \frac{3Wx}{4}$$

where $y_1(x)$ is function which defines the elastic curve for portion AC of the beam.

Integrating the equation we get,

$$EI\theta_1 = EI \frac{dy_1}{dx} = \frac{3Wx^2}{8} + C_1 \quad (22)$$

$$EIy_1 = \frac{Wx^3}{8} + C_1x + C_2 \quad (23)$$

For portion C to B ($x \geq \frac{L}{4}$)

Taking moment about any section between A and C , we have

$$M_2(x) = \frac{3Wx}{4} - W\left(x - \frac{L}{4}\right)$$

The equation of the elastic curve may be written as

$$EI \frac{d^2 y_2}{dx^2} = \frac{3Wx}{4} - W\left(x - \frac{L}{4}\right)$$

On rearrangement of terms, we get

$$EI \frac{d^2 y_2}{dx^2} = -\frac{Wx}{4} + \frac{WL}{4}$$

where $y_2(x)$ is the function which defines the elastic curve for portion CB of the beam.

Integrating the equation we get,

$$EI\theta_2 = \frac{dy_2}{dx} = -\frac{Wx^2}{8} + \frac{WLx}{4} + C_3 \quad (24)$$

$$EIy_2 = -\frac{Wx^3}{24} + \frac{WLx^2}{8} + C_3x + C_4 \quad (25)$$

Determination of constants of integration from boundary conditions and continuity conditions

Boundary conditions: At support A , $x = 0$, $y_1 = 0$ and at support B $x = L$, $y_2 = 0$

Continuity conditions: There can be no sudden change in the slope and deflection at C which requires that at $x = \frac{L}{4}$, $\theta_1 = \theta_2$ and $y_1 = y_2$

Substituting $x = 0, y_1 = 0$ in Eq. (23), we get

$$C_2 = 0$$

Substituting $x = L, y_2 = 0$ in Eq. (25), we get

$$0 = \frac{WL^3}{12} + C_3L + C_4$$

Substituting $x = \frac{L}{4}, \theta_1 = \theta_2$ into the Eq. (22) and (24) and equating the slopes at the point C , the boundary of two segments AC and CB , we get

$$\frac{3WL^2}{128} + C_1 = \frac{7WL^2}{128} + C_3$$

Substituting $x = \frac{L}{4}, y_1 = y_2$ into the Eq. (23) and (25) and equating the deflections at the point C , the boundary of two segments AC and CB , we get

$$\frac{WL^3}{512} + \frac{C_1L}{4} = \frac{11WL^3}{1536} + \frac{C_3L}{4} + C_4$$

Solving these equations simultaneously, we get

$$C_1 = -\frac{7WL^2}{128}, C_2 = 0, C_3 = -\frac{11WL^2}{128} \text{ and } C_4 = \frac{WL^3}{384}$$

Substituting C_1 and C_2 into Eq. (22) and (23) and for $x \leq \frac{L}{4}$

$$EI\theta_1 = \frac{3Wx^2}{8} - \frac{7WL^2}{128} \quad (26)$$

$$EIy_1 = \frac{Wx^3}{8} - \frac{7WL^2x}{128} \quad (27)$$

Substituting $x = \frac{L}{4}$ into Eq. (26) and (27), we get

$$\theta_c = -\frac{WL^2}{32EI} \text{ and } y_c = -\frac{3WL^3}{256EI}$$

Macaulay's method

Double integration method is a convenient and effective way for solving the slope and deflection of prismatic beam as long as the bending moment can be represented by a single function of $M(x)$. However, it is not always the case. When the loading of the beam is such that two or more functions are needed to represent the bending moment over the entire length

of the beam, as was the case in the previous problem. In such cases, additional constants of integration and as many numbers of equations become necessary to express continuity conditions at the points of load change-over in addition to the boundary conditions. Thus the process becomes lengthy and cumbersome. To overcome this difficulty, British engineer W. H. Macaulay proposed an innovative approach of solving such problems by using *singularity function* to express the bending moment over the entire length.

The execution of Macaulay's method is explained by way of solution to Problem 5.

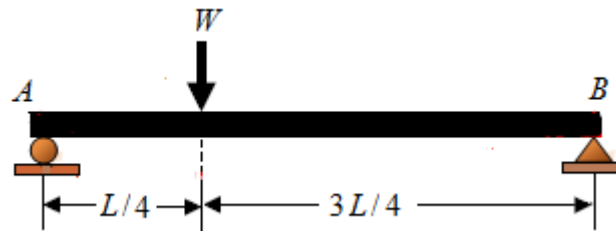

Figure 14

Solution.

Determine the support reactions

Sum of the vertical forces, $\sum V = 0,$ $R_A + R_B = W$

Sum of the vertical forces, $\sum M_B = 0,$ $R_A \times L = W \times \frac{3L}{4}$

$$R_A = \frac{3WL}{4}$$

Bending moment over the portion AC and CB of the beam may be expressed by two different functions as

$$M_1(x) = \frac{3Wx}{4} \quad \left(0 \leq x \leq \frac{L}{4} \right)$$

$$M_2(x) = \frac{3Wx}{4} - W \left(x - \frac{L}{4} \right) \quad \left(\frac{L}{4} \leq x \leq L \right)$$

where x is the distance measured from end A. The functions $M_1(x)$ and $M_2(x)$ may be represented by single expression as

$$M(x) = \frac{3Wx}{4} - W \left\langle x - \frac{L}{4} \right\rangle$$

If we want to compute slope and deflection in the portion CB i.e., when $x \geq \frac{L}{4}$, the brackets $\langle \rangle$ should be replaced by ordinary parentheses $()$. Similarly if we want to compute slope and deflection when $x < \frac{L}{4}$, the brackets $\langle \rangle$ should be replaced by zero.

Thus the equation of elastic curve over the entire length of the beam may be written as

$$EI \frac{d^2 y}{dx^2} = \frac{3Wx}{4} - W \left\langle x - \frac{L}{4} \right\rangle$$

Integrate with respect to x considering the bracket $\langle \rangle$ as a single variable.

$$EI\theta = EI \frac{dy}{dx} = \frac{3Wx^2}{8} - \frac{W}{2} \left\langle x - \frac{L}{4} \right\rangle^2 + C_1 \tag{28}$$

Follow the same rule and integrate again with respect to x .

$$EIy = \frac{Wx^3}{8} - \frac{W}{6} \left\langle x - \frac{L}{4} \right\rangle^3 + C_1x + C_2 \quad (29)$$

The constants C_1 and C_2 may be determined from the boundary conditions.

At $x = 0, y = 0$ and at $x = L, y = 0$

For $x = 0 < \frac{L}{4}$, the brackets are equal to zero, hence $C_2 = 0$

For $x = L \geq \frac{L}{4}$, the brackets may be replaced by parentheses,

$$0 = \frac{WL^3}{8} - \frac{W}{6} \left(L - \frac{L}{4} \right)^3 + C_1L$$

$$0 = \frac{WL^3}{8} - \frac{9WL^3}{128} + C_1L$$

$$C_1 = -\frac{7WL^2}{128}$$

Substituting the value of C_1 in Eq. (28) and C_1 and C_2 in Eq. (29), we get

$$\text{General equation for slope} \quad EI\theta = EI \frac{dy}{dx} = \frac{3Wx^2}{8} - \frac{W}{2} \left\langle x - \frac{L}{4} \right\rangle^2 - \frac{7WL^2}{128} \quad (30)$$

$$\text{General equation for deflection} \quad EIy = \frac{Wx^3}{8} - \frac{W}{6} \left\langle x - \frac{L}{4} \right\rangle^3 - \frac{7WL^2}{128}x \quad (31)$$

The need for additional constants C_3 and C_4 as in Problem 5 has been eliminated and hence need for writing additional equations of continuity for slope deflection.

Substituting the value of $x = \frac{L}{4}$ in each of the above equations, we get

$$\theta_c = -\frac{WL^2}{32EI} \text{ and}$$

$$y_c = -\frac{3WL^3}{256EI}$$

Problem 6.

Determine the slope and deflection at points B of the beam shown in the Figure. 15. Take $E = 200 \text{ GPa}$ and $I = 250(10^6) \text{ mm}^4$.

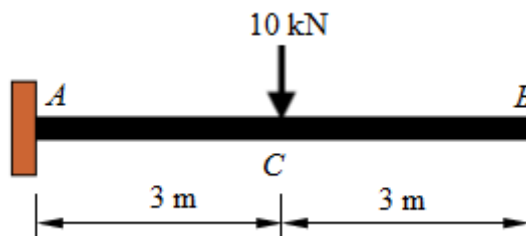

Figure 15

Solution.

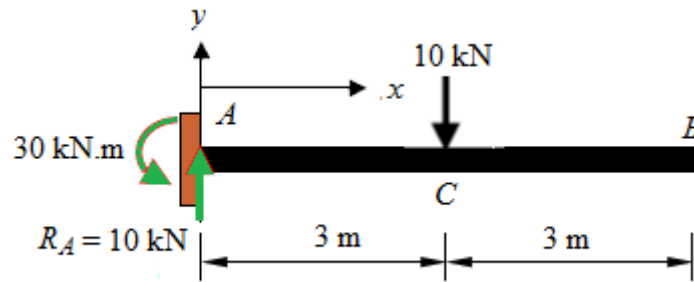

Figure 16

Determine the support reactions

Sum of the vertical forces, $\sum V = 0$, $R_A = 10 \text{ kN}$

Sum of the vertical forces, $\sum M_A = 0$, $M_A = 10 \times 3 = 30 \text{ kN.m}$

Considering from the left hand side and taking moment about any section between C and B, we have

$$M(x) = 10x - 30 - 10(x - 3)$$

Do not simplify. On simplification the moment becomes zero between B and C which is obvious.

Thus the equation of elastic curve over the entire length of the beam may be written as

$$EI \frac{d^2 y}{dx^2} = 10x - 30 - 10\langle x - 3 \rangle$$

Integrate with respect to x considering the bracket $\langle \rangle$ as a single variable.

$$EI\theta = EI \frac{dy}{dx} = 5x^2 - 30x - 5\langle x - 3 \rangle^2 + C_1 \quad (32)$$

Follow the same rule and integrate again with respect to x .

$$EIy = \frac{5}{3}x^3 - 15x^2 - \frac{5}{3}\langle x - 3 \rangle^3 + C_1x + C_2 \quad (33)$$

The constants C_1 and C_2 may be determined from the boundary conditions.

At $x = 0$, $\theta = 0$ and $x = 0$, $y = 0$

For $x = 0 < 3 \text{ m}$, the brackets are equal to zero, hence from Eq. (32) $C_1 = 0$ and from Eq. (33) $C_2 = 0$

Substituting the values of C_1 and C_2 in Eq. (32) and (33), we get

$$\text{General equation for slope} \quad EI\theta = EI \frac{dy}{dx} = 5x^2 - 30x - 5\langle x - 3 \rangle^2 \quad (34)$$

$$\text{General equation for deflection} \quad EIy = \frac{5}{3}x^3 - 15x^2 - \frac{5}{3}\langle x - 3 \rangle^3 \quad (35)$$

Substituting the value of $x = 6$ in each of the above equations, we get

From Eq. (34) the slope,

$$EI\theta_B = 5(6)^2 - 30 \times 6 - 5(6-3)^2$$

$$\theta_B = -\frac{45}{EI}$$

$$\theta_B = -\frac{45 \text{ kN.m}^2}{\left(200 \times 10^6 \frac{\text{kN}}{\text{m}^2}\right) \times (250 \times 10^{-6} \text{ m}^4)}$$

$$\theta_B = -0.0009 \text{ radian}$$

From Eq. (35), the deflection

$$EIy_B = \frac{5}{3}(6)^3 - 15(6)^2 - \frac{5}{3}(6-3)^3$$

$$EIy_B = 360 - 540 - 45$$

$$y_B = -\frac{225}{EI}$$

$$y_B = -\frac{225 \text{ kN.m}^3}{\left(200 \times 10^6 \frac{\text{kN}}{\text{m}^2}\right) \times (250 \times 10^{-6} \text{ m}^4)}$$

$$y_B = -0.0045 \text{ m} = -4.5 \text{ mm}$$

For the equation of elastic curve between A and C, neglecting the bracketed term in Eq. (35), we get

$$EIy = \frac{5}{3}x^3 - 15x^2 \text{ which is cubic}$$

For the equation of elastic curve between C and B, considering the bracketed term in Eq. (35) and replacing with parentheses, we get

$$EIy = \frac{5}{3}x^3 - 15x^2 - \frac{5}{3}(x-3)^3$$

$$EIy = \frac{5}{3}x^3 - 15x^2 - \frac{5}{3}(x^3 - 9x^2 - 27x + 27)$$

$$EIy = 45x - 45 \text{ which is linear}$$

The elastic curve of the beam with the salient points is shown in the figure

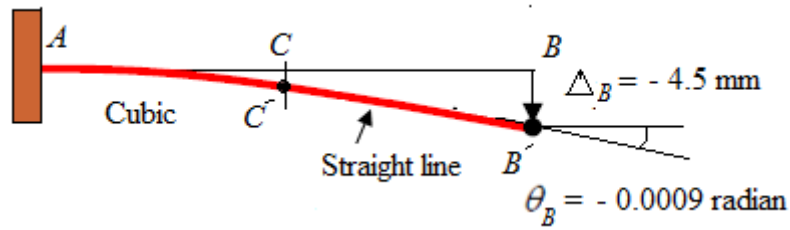

Problem 7.

The cantilevered beam shown is subjected to a uniformly distributed load w per unit length. Determine the slope and deflection at point C and B . Also draw the elastic curve. EI is constant.

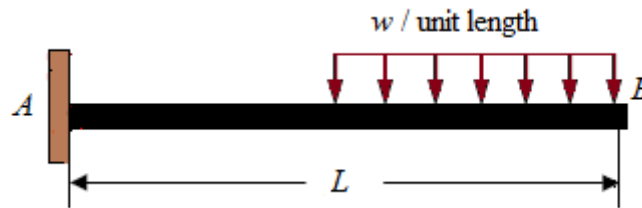

Figure 17

Solution.

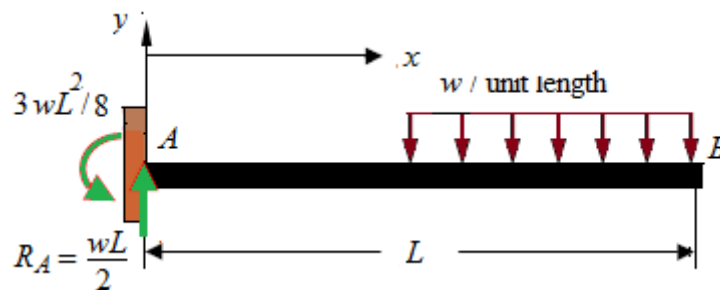

Figure 18

Determine the support reactions

Sum of the vertical forces, $\sum V = 0$, $R_A = \frac{wL}{2}$

Sum of the vertical forces, $\sum M_A = 0$, $M_A = -\frac{wL}{2} \times \frac{3L}{4} = -\frac{3wL^2}{8}$

Considering from the left hand side and taking moment about any section between C and B , we have

$$M(x) = -\frac{3wL^2}{8} + \frac{wL}{2}x - \frac{w}{2}\left(x - \frac{L}{2}\right)^2$$

Following Macaulay's method, the equation of elastic curve over the entire length of the beam may be written as

$$EI \frac{d^2 y}{dx^2} = -\frac{3wL^2}{8} + \frac{wL}{2}x - \frac{w}{2} \left\langle x - \frac{L}{2} \right\rangle^2$$

Integrate with respect to x considering the bracket $\langle \rangle$ as a single variable.

$$EI\theta = EI \frac{dy}{dx} = -\frac{3wL^2 x}{8} + \frac{wLx^2}{4} - \frac{w}{6} \left\langle x - \frac{L}{2} \right\rangle^3 + C_1 \quad (36)$$

Follow the same rule and integrate again with respect to x .

$$EIy = -\frac{3wL^2 x^2}{16} + \frac{wLx^3}{12} - \frac{w}{24} \left\langle x - \frac{L}{2} \right\rangle^4 + C_1 x + C_2 \quad (37)$$

The constants C_1 and C_2 may be determined from the boundary conditions.

At $x = 0$, $\theta = 0$ and $x = 0$ m, $y = 0$

For $x = 0 < \frac{L}{2}$, the brackets are equal to zero, hence from Eq. (36) $C_1 = 0$ and from Eq. (37) $C_2 = 0$

Substituting the values of C_1 and C_2 in Eq. (36) and (37), we get

General equation for slope $EI\theta = EI \frac{dy}{dx} = -\frac{3wL^2 x}{8} + \frac{wLx^2}{4} - \frac{w}{6} \left\langle x - \frac{L}{2} \right\rangle^3 \quad (38)$

General equation for deflection $EIy = -\frac{3wL^2 x^2}{16} + \frac{wLx^3}{12} - \frac{w}{24} \left\langle x - \frac{L}{2} \right\rangle^4 \quad (39)$

Substituting the value of $x < \frac{L}{2}$ in each of the above equations and equating the bracketed term as zero, we get

From Eq. (37) the slope at C , $EI\theta_C = -\frac{3wL^2}{8} \frac{L}{2} + \frac{wL}{4} \left(\frac{L}{2} \right)^2$

$$EI\theta_C = -\frac{3wL^3}{16} + \frac{wL^3}{16}$$

$$\theta_C = -\frac{wL^3}{8EI}$$

From Eq. (39) the deflection at C, $EIy = -\frac{3wL^2}{16}\left(\frac{L}{2}\right)^2 + \frac{wL}{12}\left(\frac{L}{2}\right)^3$

$$EIy = -\frac{3wL^4}{64} + \frac{wL^4}{96}$$

$$y_c = -\frac{7wL^4}{192EI}$$

Substituting the value of $x < L$ in Eq. (38) and (39) and replacing the brackets by parentheses, we get

From Eq. (38) the slope at B, $EI\theta_B = -\frac{3wL^2L}{8} + \frac{wL}{4}L^2 - \frac{w}{6}\left(L - \frac{L}{2}\right)^3$

$$EI\theta_B = -\frac{3wL^3}{8} + \frac{wL^3}{4} - \frac{wL^3}{48}$$

$$\theta_B = -\frac{7wL^3}{48EI}$$

From Eq. (39) the deflection at B, $EIy_B = -\frac{3wL^2L^2}{16} + \frac{wLL^3}{12} - \frac{w}{24}\left(L - \frac{L}{2}\right)^4$

$$EIy_B = -\frac{3wL^4}{16} + \frac{wL^4}{12} - \frac{wL^4}{384}$$

$$y_B = -\frac{41wL^4}{384EI}$$

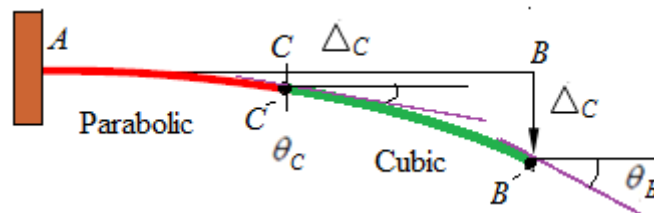

Figure

Problem 8.

Determine the maximum deflection, the slope and deflection at points C of the beam shown in the figure. Also, draw the elastic curve of the beam. Take $E = 200 \text{ GPa}$ and $I = 60(10^6) \text{ mm}^4$.

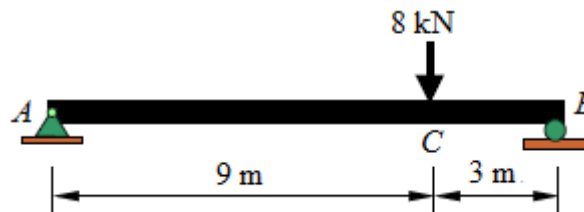

Figure 19

Solution.

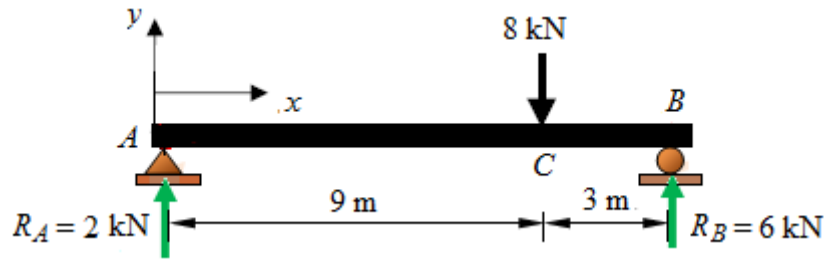

Figure 20

Determine the support reactions

$$\text{Sum of the vertical forces, } \sum V = 0, \quad R_A + R_B = 8$$

$$\text{Sum of the vertical forces, } \sum M_B = 0, \quad R_A \times 12 = 8 \times 3$$

$$R_A = 2 \text{ kN}$$

Considering from the left hand side and taking moment about any section between C and B, we have

$$M(x) = 2x - 8(x - 9)$$

Following Macaulay's method, the equation of elastic curve over the entire length of the beam may be written as

$$EI \frac{d^2 y}{dx^2} = 2x - 8\langle x - 9 \rangle$$

Integrate with respect to x considering the bracket $\langle \ \rangle$ as a single variable.

$$EI\theta = EI \frac{dy}{dx} = x^2 - 4\langle x - 9 \rangle^2 + C_1 \quad (40)$$

Follow the same rule and integrate again with respect to x .

$$EIy = \frac{1}{3}x^3 - \frac{4}{3}\langle x - 9 \rangle^3 + C_1x + C_2 \quad (41)$$

The constants C_1 and C_2 may be determined from the boundary conditions.

At $x = 0$, $y = 0$ and $x = 12 \text{ m}$, $y = 0$

For $x = 0 < 9 \text{ m}$, the brackets are equal to zero, hence from Eq. (41) $C_2 = 0$

and for $x = 12 > 6$, from Eq. (41)

$$EI(0) = \frac{1}{3}12^3 - \frac{4}{3}(12 - 9)^3 + C_1 \times 12$$

$$12C_1 = -\frac{1}{3}12^3 + \frac{4}{3}(12-9)^3$$

$$C_1 = -45$$

Substituting the values of C_1 and C_2 in Eq. (40) and (41), we get

$$\text{General equation for slope} \quad EI\theta = EI \frac{dy}{dx} = x^2 - 4\langle x-9 \rangle^2 - 45 \quad (42)$$

$$\text{General equation for deflection} \quad EIy = \frac{1}{3}x^3 - \frac{4}{3}\langle x-9 \rangle^3 - 45x \quad (43)$$

Substituting the value of $x < 4$ in each of the above equations, we get

$$\text{From Eq. (42) the slope,} \quad EI\theta_B = (9)^2 - 45$$

$$\theta_B = \frac{36}{EI}$$

$$\theta_B = \frac{36 \text{ kN.m}^2}{\left(200 \times 10^6 \frac{\text{kN}}{\text{m}^2}\right) \times (60 \times 10^{-6} \text{ m}^4)}$$

$$\theta_B = 0.003 \text{ radian}$$

$$\text{From Eq. (43), the deflection} \quad EIy_B = \frac{1}{3}(9)^3 - 45 \times 9$$

$$y_B = -\frac{162}{EI}$$

$$y_B = -\frac{162 \text{ kN.m}^3}{\left(200 \times 10^6 \frac{\text{kN}}{\text{m}^2}\right) \times (60 \times 10^{-6} \text{ m}^4)}$$

$$y_B = -0.0135 \text{ m} = -13.5 \text{ mm}$$

For maximum deflection, the slope must be zero.

Let us assume that the maximum slope would occur in the portion AC, equating the slope equation in (42) without the bracketed term to zero

$$x^2 - 45 = 0 \text{ assa}$$

$$x = \pm\sqrt{45} = \pm 6.708 \text{ m}$$

Neglecting the - ve sign, the deflection would occur at $x = 6.708 \text{ m}$

Maximum deflection, $EIy_{\max} = \frac{1}{3}(6.708)^3 - 45 \times 6.708$

$$EIy_{\max} = \frac{1}{3}(6.708)^3 - 45 \times 6.708$$

$$y_{\max} = -\frac{200.246}{EI}$$

$$y_{\max} = -\frac{200.246 \text{ kN.m}^3}{\left(200 \times 10^6 \frac{\text{kN}}{\text{m}^2}\right) \times \left(60 \times 10^{-6} \text{ m}^4\right)}$$

$$y_{\max} = -0.01668 \text{ m} = -16.68 \text{ mm}$$

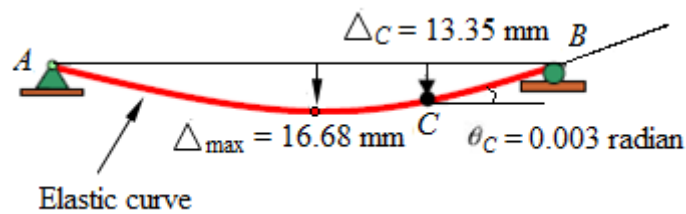

Problem 9.

Determine the slope and deflection at points C of the beam shown in the Figure. 15. Take $E = 200 \text{ GPa}$ and $I = 250(10^6) \text{ mm}^4$.

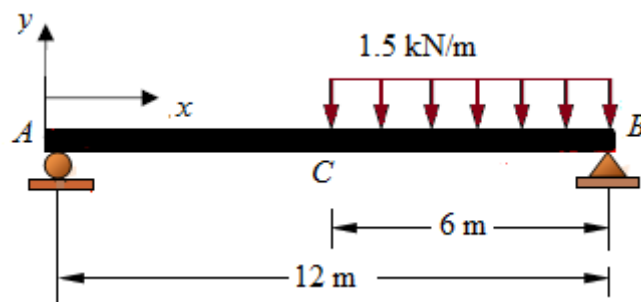
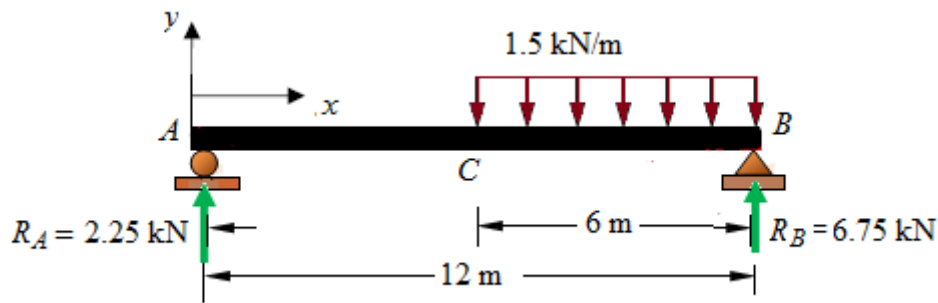

Figure 21

Solution.



Determine the support reactions

$$\text{Sum of the vertical forces, } \sum V = 0, \quad R_A + R_B = 1.5 \times 6 = 9$$

$$\text{Sum of the vertical forces, } \sum M_B = 0, \quad R_A \times 12 = 1.5 \times 6 \times \frac{6}{2}$$

$$R_A = 2.25 \text{ kN}$$

Considering from the left hand side and taking moment about any section between C and B, we have

$$\begin{aligned} M(x) &= 2.5x - 1.5(x-6) \frac{(x-6)}{2} \\ &= 2.5x - 0.75(x-6)^2 \end{aligned}$$

Following Macaulay's method, the equation of elastic curve over the entire length of the beam may be written as

$$EI \frac{d^2 y}{dx^2} = 2.5x - 0.75 \langle x-6 \rangle^2$$

Integrate with respect to x considering the bracket $\langle \rangle$ as a single variable.

$$EI\theta = EI \frac{dy}{dx} = 1.25x^2 - 0.25 \langle x-6 \rangle^3 + C_1 \quad ()$$

Follow the same rule and integrate again with respect to x .

$$EIy = \frac{1.25}{3} x^3 - \frac{0.25}{4} \langle x-6 \rangle^4 + C_1 x + C_2 \quad (41)$$

The constants C_1 and C_2 may be determined from the boundary conditions.

At $x = 0$, $y = 0$ and $x = 12$ m, $y = 0$

For $x = 0 < 6$ m, the brackets are equal to zero, hence from Eq. () $C_2 = 0$

and $x = 12 > 6$ from Eq. () the brackets being replaced with parentheses

$$EI(0) = \frac{1.25}{3} \times 12^3 - \frac{0.25}{4} (12-6)^4 + 12C_1$$

$$12C_1 = -720 + 81$$

$$C_1 = -\frac{639}{12} = -53.25$$

Substituting the values of C_1 and C_2 in Eq. (40) and (41), we get

$$EI\theta = EI \frac{dy}{dx} = 1.25x^2 - 0.25\langle x-6 \rangle^3 - 53.25$$

$$EIy = \frac{1.25}{3}x^3 - \frac{0.25}{4}\langle x-6 \rangle^4 - 53.25x$$

Slope and deflection of commonly loaded simply supported beam

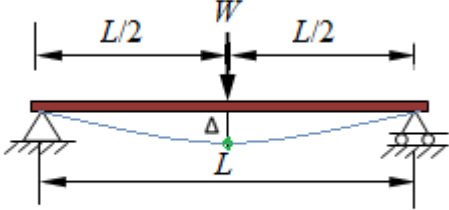
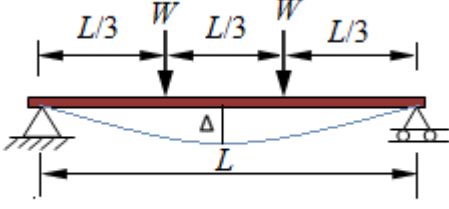
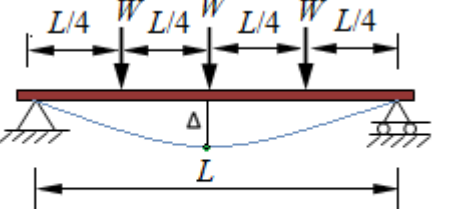
Beam load and support	Deflection
 <p>(a) Point load at mid-span</p>	<p>At centre $\Delta_{\max} = \frac{WL^3}{48EI}$</p>
 <p>(b) Two equal point loads at third points</p>	<p>At centre $\Delta_{\max} = \frac{23WL^3}{648EI}$</p>
 <p>(c) Three equal point loads at quarter points</p>	<p>At centre $\Delta_{\max} = \frac{WL^3}{20.1EI}$</p>

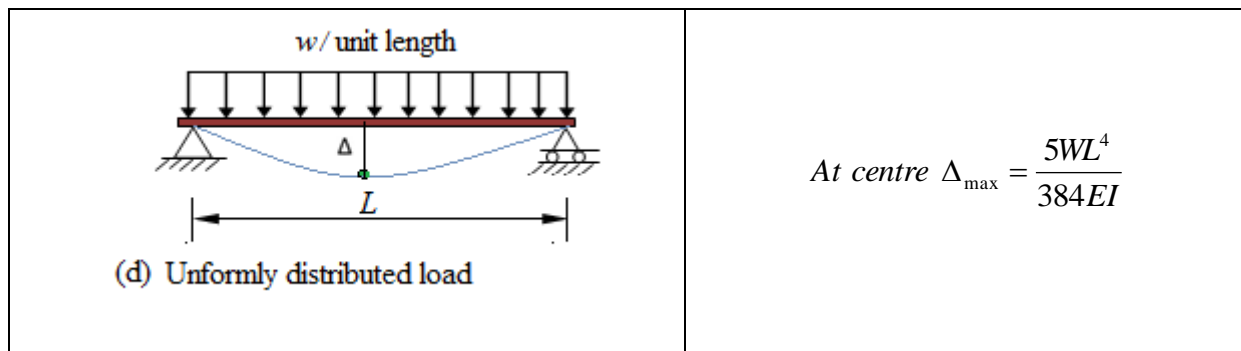

Principle of superimposition

For linear response structures, the structural responses such as slope and deflection due to several loads acting simultaneously may be obtained by superposing the effects of individual loads. This is called principle of superposition.

The principle of superposition is valid under the following conditions

1. Hooke's law holds for the material
2. the deflections and rotations are small
3. the presence of the deflection does not alter the actions of applied loads

These requirements ensure that the differential equations of the deflection curve are linear. A very useful application of the principle of superposition is to determine the deflection of statically indeterminate beams. In the present discourse we will restrict our study only to propped cantilever which falls within the scope of the syllabus.

MOMENT-AREA METHOD

Introduction

In this section we will discuss on the evaluation of slope and deflection of beams employing moment-area method. Unlike previous section, beams with non-uniform EI or flexural rigidity can be dealt with. Slope and deflection of non-prismatic beams with continuously varying moment of inertia can be conveniently determined.

Moment- Area Method

The moment-area method is one of the most effective methods for obtaining the bending displacement in beams and frames. For problems involving several changes in loading, the area-moment method is usually much faster than the double-integration method; consequently, it is widely used in practice. In this method, the area of the bending moment diagrams is utilized for computing the slope and or deflections at particular points along the

axis of the beam or frame. Two theorems known as the moment area theorems are utilized for calculation of the deflection. One theorem is used to calculate the change in the slope between two points on the elastic curve. The other theorem is used to compute the vertical distance (called tangential deviation) between a point on the elastic curve and a line tangent to the elastic curve at a second point.

Theorem I:

The change in slope between the tangents to the elastic curve at any two points on a straight member under bending is equal to the area of the M/EI diagram between these two points.

Theorem II:

The vertical deflection of a point B on an elastic curve of a straight member under bending in the direction perpendicular to the original straight axis, with respect to the tangent drawn at another point A on the member, is equal to the moment of the area under the M/EI diagram between those two points about the point B where this deflection occurs.

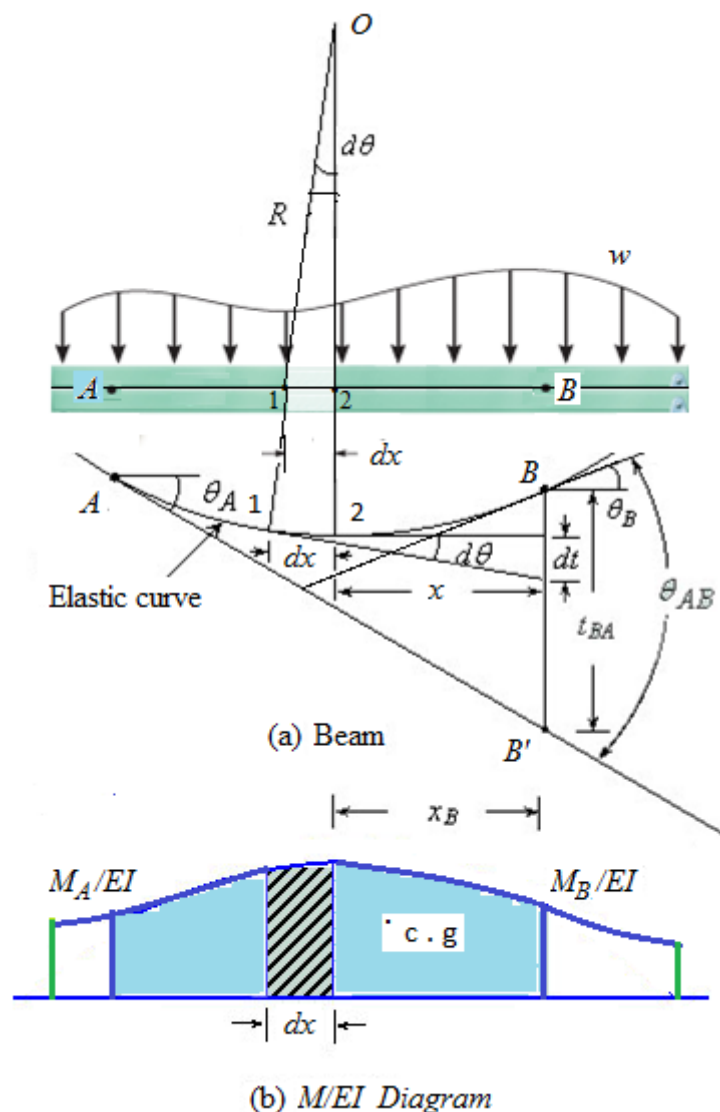

Figure 1

Derivation

Consider Figure 1 showing the elastic curve of a loaded beam. On the elastic curve tangents are drawn on points A and B . Total angle between the two tangents is denoted as θ_{AB} . Take any two points 1 and 2 at a distance dx apart on the straight beam. The distance between these two points on the elastic curve is same as dx (assumption).

In order to find out θ_{AB} , consider the incremental change in angle $d\theta$ over an infinitesimal segment dx located at a distance of x from point B . The radius of curvature R and bending moment M for any section of the beam is given by the usual bending equation (Theory of bending).

$$\frac{M}{I} = \frac{E}{R} \quad (1)$$

where E is the Young's modulus and I is the moment of inertia
The elementary length dx and the change in angle $d\theta$ are related as,

$$dx = d\theta \times R \quad (2)$$

Substituting R from Eq. (2) in Eq. (1)

$$d\theta = \frac{M}{EI} dx \quad (3)$$

The total angle change can be obtained by integrating Eq. (3) between points A and B which is expressed as

$$\Delta\theta_{AB} = \int_A^B d\theta = \int_A^B \frac{M}{EI} dx \quad (4)$$

$$\theta_B - \theta_A = \text{Area of } M/EI \text{ diagram between } A \text{ and } B$$

Change in slope between the tangents drawn at any two points on the elastic curve

$$= \text{Area of } \frac{M}{EI} \text{ diagram between the two points on straight beam}$$

The distance dt along the vertical line through point B is nearly equal to

$$dt = x \times d\theta$$

Integration of dt between points A and B yields the vertical distance between the point B and the tangent from point A on the elastic curve. Thus,

$$t_{BA} = \int_A^B x d\theta = \int_A^B \frac{Mx}{EI} dx \quad (5)$$

Vertical deflection of second point with respect to the tangent drawn at first point

= Moment of Area of $\frac{M}{EI}$ diagram between the two points on the straight beam about the second point at which the vertical deflection is required

Sign convention

The deviation at any point on the elastic curve is positive if the point lies above the tangent, negative if the point is below the tangent; we measured it from left tangent, if θ is counter-clockwise direction, the change in slope is positive, negative if θ is clockwise direction.

Procedure for analysis

1. Sketch the loaded beam and determine the support reactions from equations of static equilibrium.
2. Draw the moment or M/EI diagrams (either by parts or composite diagram, depending on the complexity of the problem).
3. Draw the elastic curve. A beam subjected to +ve bending moment bends concave up, whereas -ve moment bends the beam concave down.
4. Identify a point of zero slope if any, either from symmetry or from supports. A tangent drawn at this point will frequently be useful. Visualize which tangent lines may be most helpful, and draw such lines on the elastic curve.
5. By application of the second area-moment theorem, determine the tangential deviation at the point where the beam deflection is desired and at any other points required.
6. From geometry, determine the perpendicular distance from the unloaded beam to the tangent line at the point where the beam deflection is desired, and, using the results of step 3, solve for the required deflection.

Slope and deflection of cantilever beam

Slope and deflection of simple supported beam

Geometric properties of common plane figures

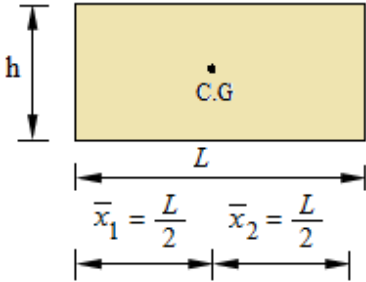
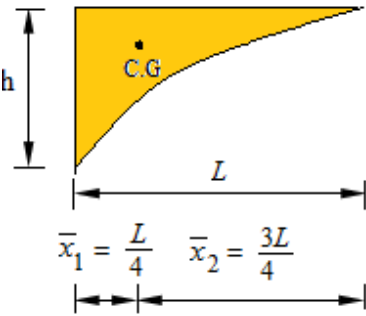
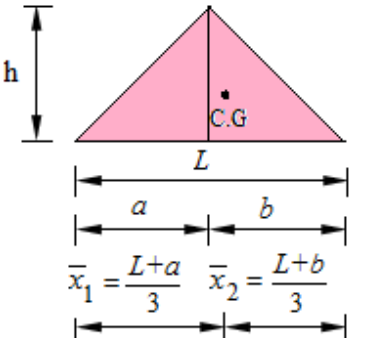
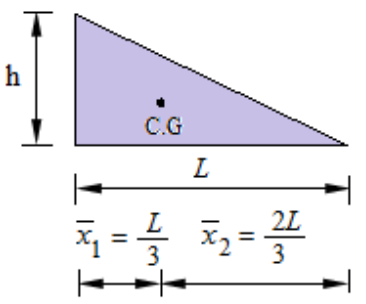
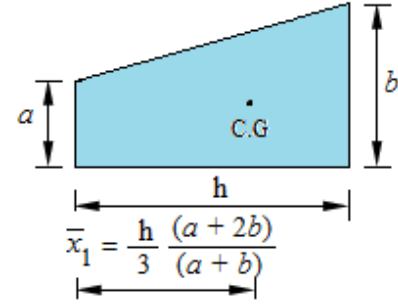
Sl. No.	Name of figure	Diagram	Area
1	Rectangle	 <p> $\bar{x}_1 = \frac{L}{2}$ $\bar{x}_2 = \frac{L}{2}$ </p>	Area = Lh
2	Square parabola	 <p> $\bar{x}_1 = \frac{L}{4}$ $\bar{x}_2 = \frac{3L}{4}$ </p>	Area = $\frac{1}{3}Lh$
3	Triangle	 <p> $\bar{x}_1 = \frac{L+a}{3}$ $\bar{x}_2 = \frac{L+b}{3}$ </p>	Area = $\frac{1}{2}Lh$
4	Right-angled triangle	 <p> $\bar{x}_1 = \frac{L}{3}$ $\bar{x}_2 = \frac{2L}{3}$ </p>	Area = $\frac{1}{2}Lh$
5	Trapezium	 <p> $\bar{x}_1 = \frac{h}{3} \frac{(a+2b)}{(a+b)}$ </p>	Area = $\frac{1}{2}h(a+b)$

Section I: Cantilever beam

Problem 1.

A cantilever of span L carries a point load W at the free end. Determine the slope and deflection at the free end.

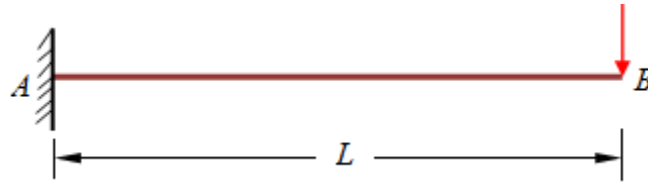

Figure 2

Solution.

Determine the support reactions,

Sum of the vertical forces, $\Sigma V = 0$;

$$R_A = W$$

Sum of the moments about A, $\Sigma M_A = 0$;

$$M_A = -WL$$

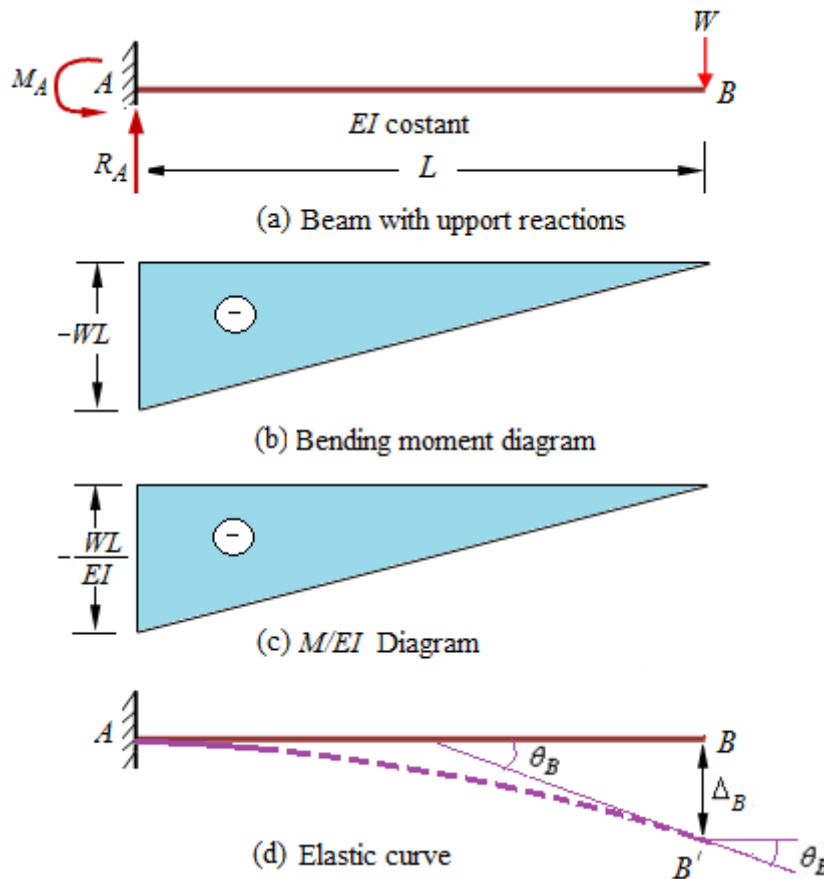

Figure 2

Draw bending moment diagram as shown in the Figure 2(b) and M/EI diagram by dividing ordinate of the bending moment diagram by EI as shown in Figure 2(c).

Draw an exaggerated shape of the probable elastic curve as shown in Figure 2(d). It is known that the tangent drawn at fixed end A on the elastic curve would follow the original beam, hence slope at A, $\theta_A = 0$. Let the slope at B be θ_B .

Applying first theorem of moment-area

The change in slope between the tangents drawn at two points on the elastic curve,

$$\theta_{AB} = \theta_B - \theta_A = \text{Area of the } M/EI \text{ diagram between A and B}$$

$$\theta_B - 0 = \frac{1}{2}L \times \left(-\frac{WL}{EI}\right)$$

$$\theta_B = -\frac{WL^2}{2EI} \quad (\text{Clockwise rotation})$$

Applying second theorem of moment-area

The tangential deviation of point B with respect to the tangent drawn at point A which in this case is also the deflection of free end B with respect to the original beam position,

$$\Delta_B = \text{Moment of the area of } M/EI \text{ diagram about point } B$$

$$\Delta_B = \frac{1}{2}L \times \left(-\frac{WL}{EI}\right) \times \frac{2L}{3}$$

$$\Delta_B = -\frac{WL^2}{3EI} \quad (\text{Downward deflection})$$

Problem 2.

A cantilever of span L carries a point load W at a distance of a , from the fixed end. Determine the slope and deflection at the free end.

Solution.

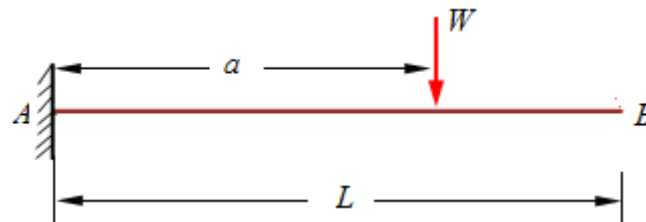

Figure 3

Determine the support reactions,

$$\text{Sum of the vertical forces, } \Sigma V = 0; \quad R_A = W$$

$$\text{Sum of the moments about A, } \Sigma M_A = 0; \quad M_A = -Wa$$

Draw bending moment diagram as shown in the Figure 4(b) and M/EI diagram by dividing ordinate of the bending moment diagram by EI as shown in Figure 4(c).

Draw an exaggerated shape of the probable elastic curve as shown in Figure 4(d). It is known that the tangent drawn at fixed end A on the elastic curve would follow the original beam, hence slope at A , $\theta_A = 0$. The portion CB of the elastic curve would remain as straight as there is no loading on the original cantilever. Let the slope at C be θ_C . The slope at B is also the same as θ_C .

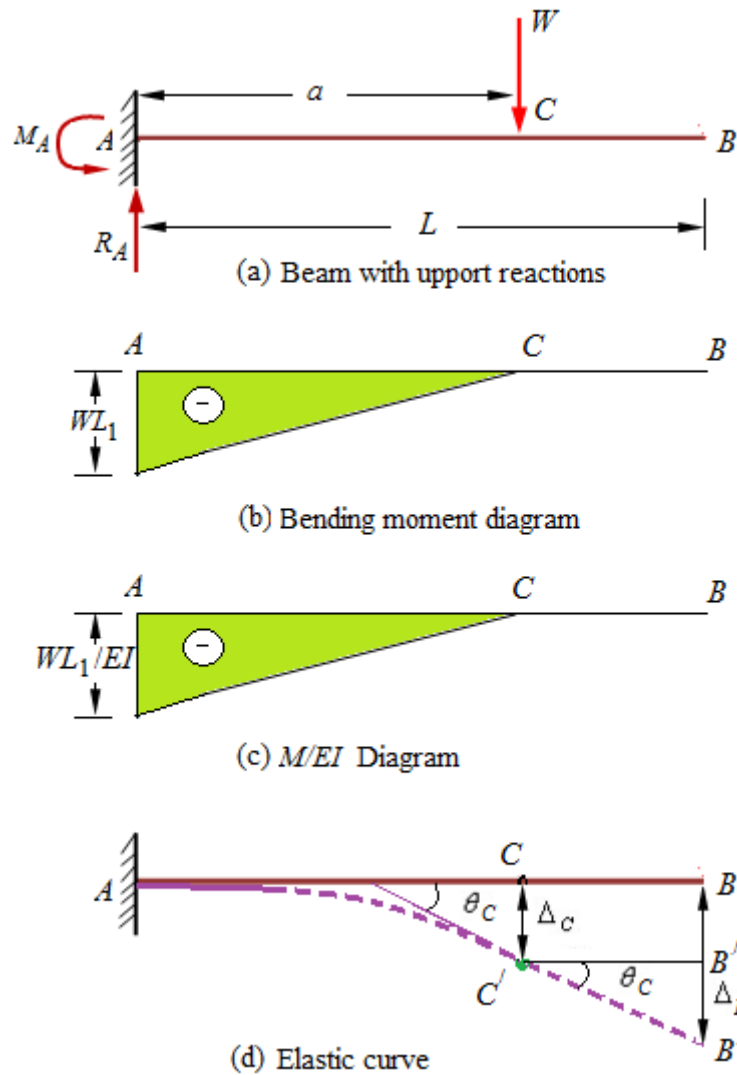

Figure 4

Applying first theorem of moment-area

The change in slope between the tangents drawn at points A and C on the elastic curve,

$$\theta_{AC} = \theta_C - \theta_A = \text{Area of the } M/EI \text{ diagram between A and C}$$

$$\theta_C - 0 = \frac{1}{2} a \times \left(-\frac{Wa}{EI} \right)$$

$$\theta_C = -\frac{Wa^2}{2EI} \quad (\text{Clockwise rotation})$$

Applying second theorem of moment-area

The tangential deviation of point B with respect to the tangent drawn at point A which in this case is also the deflection of free end B with respect to the original beam position,

$$\Delta_C = \text{Moment of the area of } M/EI \text{ diagram about point C}$$

$$\Delta_C = \frac{1}{2} a \times \left(-\frac{Wa}{EI} \right) \times \frac{2a}{3}$$

$$\Delta_C = -\frac{Wa^3}{3EI} \quad (\text{Downward deflection})$$

From geometry of the elastic curve,

$$\text{Slope at free end, } B \theta_B = \theta_C = -\frac{Wa^2}{2EI}$$

Deflection at B, $\Delta_B = BB' = BB'' + B''B' = \Delta_C + (L-a)\theta_C$

$$\Delta_B = \frac{Wa^3}{3EI} + (L-a)\frac{Wa^2}{2EI}$$

$$\Delta_B = \frac{Wa^3}{3EI} + \frac{Wa^2L}{2EI} - \frac{Wa^3}{2EI}$$

$$\Delta_B = \frac{Wa^2L}{2EI} - \frac{Wa^3}{6EI}$$

Problem 3.

A cantilever beam of length L carries a uniformly distributed load of w /unit length throughout its length. Determine the slope and deflection at its free end.

Solution.

Sum of the vertical forces, $\Sigma V = 0$; $R_A = W$

Sum of the moments about A, $\Sigma M_A = 0$; $M_A = -WL \frac{L}{2} = -\frac{WL^2}{2}$

Draw M/EI diagram by dividing ordinate of the bending moment diagram by EI as shown in Figure 5(b).

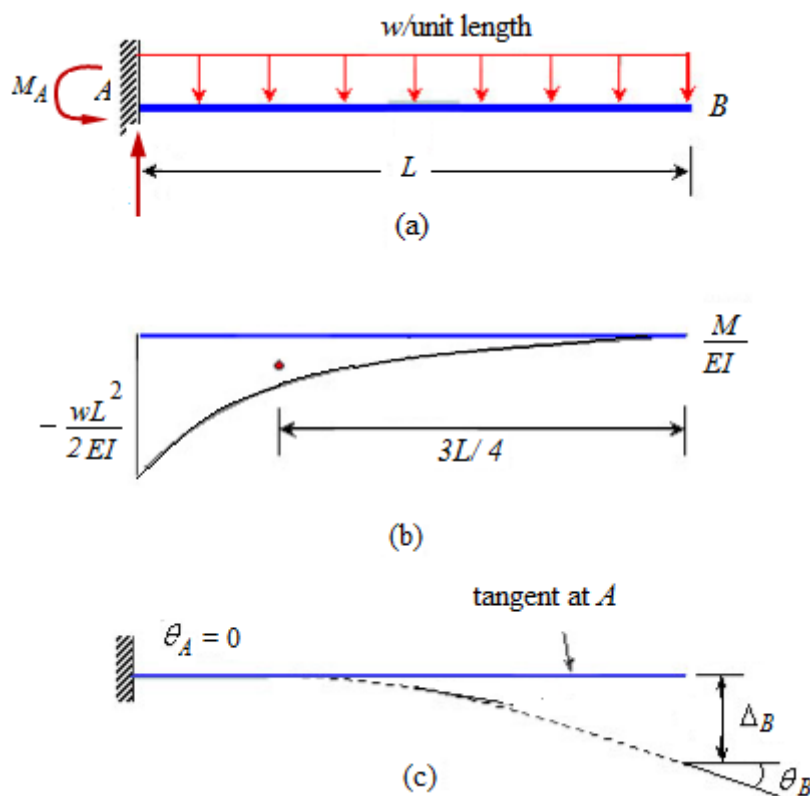

Figure 5

Applying first theorem of moment-area

The change in slope between the tangents drawn at two points on the elastic curve,

$$\theta_{AB} = \theta_B - \theta_A = \text{Area of the } M/EI \text{ diagram between A and B}$$

$$\theta_B - 0 = -\frac{1}{3} L \times \left(\frac{WL^2}{2EI} \right)$$

$$\theta_B = -\frac{WL^3}{6EI} \quad (\text{Clockwise rotation})$$

Applying second theorem of moment-area

The tangential deviation of point B with respect to the tangent drawn at point A which in this case is also the deflection of free end B with respect to the original beam position,

$$\Delta_B = \text{Moment of the area of } M/EI \text{ diagram about point } B$$

$$\Delta_B = \frac{1}{3}L \times \left(-\frac{WL^2}{2EI}\right) \times \frac{3L}{4}$$

$$\Delta_B = -\frac{WL^4}{8EI} \quad (\text{Downward deflection})$$

Problem 4.

Using the moment area method, determine the slope and deflection at free end B of the cantilever beam as shown in Figure 6. The beam is subjected to uniformly distributed load over entire length and point load at the free end.

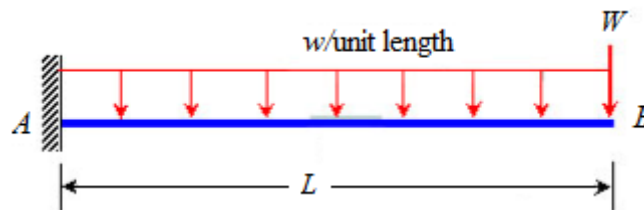

Figure 6

Solution.

Determine the support reactions,

$$\text{Sum of the vertical forces, } \Sigma V = 0; \quad R_A = W$$

Instead of drawing composite M/EI diagram, it is convenient to M/EI diagrams in parts, one each for point load and uniformly distributed load.

Bending moment about A due to point load W , $M_1 = -WL$

$$\text{Bending moment about A due to } udl, \quad M_2 = -wL \frac{L}{2} = -\frac{wL^2}{2}$$

Applying first theorem of moment-area

The change in slope between the tangents drawn at two points on the elastic curve,

$$\theta_{AB} = \theta_B - \theta_A = \text{Area of the } M/EI \text{ diagram between A and B}$$

$$\theta_B - 0 = \frac{1}{2}L \times \left(-\frac{WL}{EI}\right) + \frac{1}{3}L \times \left(-\frac{wL^2}{2EI}\right)$$

$$\theta_B = -\frac{WL^2}{2EI} - \frac{wL^3}{6EI} \quad (\text{Clockwise rotation})$$

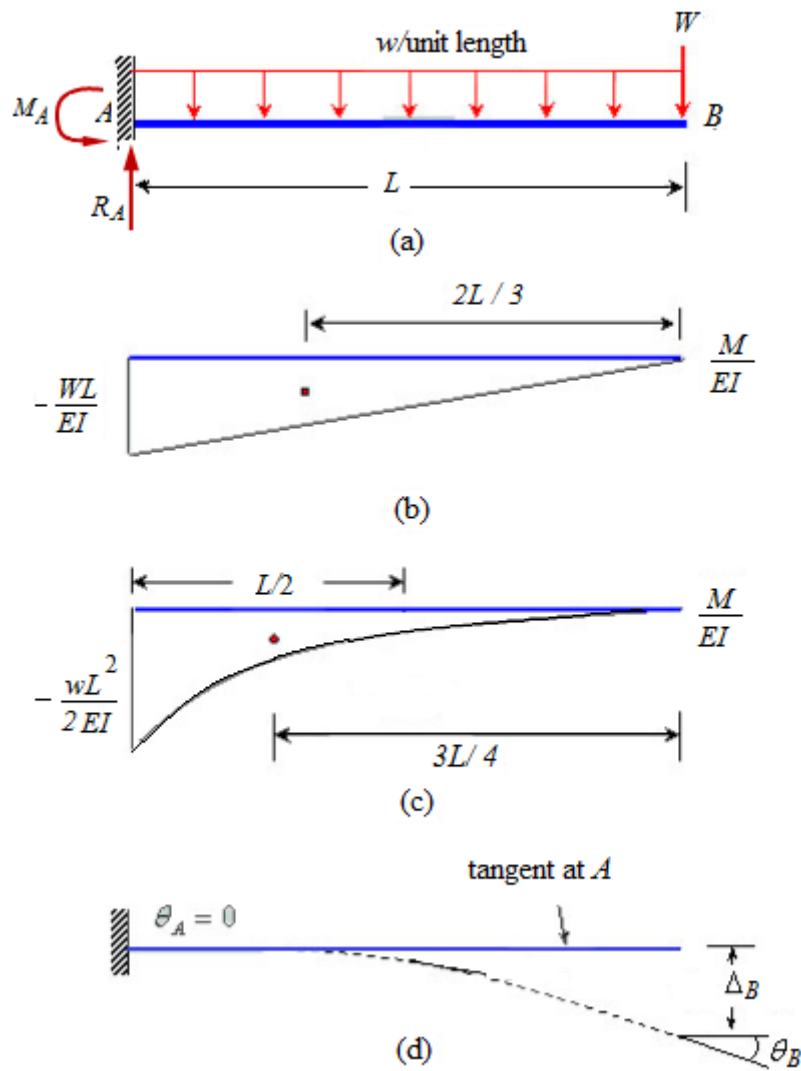

Figure 7

Applying second theorem of moment-area

The tangential deviation of point B with respect to the tangent drawn at point A which in this case is also the deflection of free end B with respect to the original beam position,

$$\Delta_B = \text{Moment of the area of } M/EI \text{ diagram between about point } B$$

$$\Delta_B = \frac{1}{2} L \times \left(-\frac{WL}{EI} \right) \times \frac{2L}{3} - \frac{1}{3} L \times \left(\frac{WL^2}{2EI} \right) \times \frac{2L}{3}$$

$$\Delta_B = \frac{1}{2} L \times \left(-\frac{WL}{EI} \right) \times \frac{2L}{3} + \frac{1}{3} L \times \left(-\frac{WL^2}{2EI} \right) \times \frac{3L}{4}$$

$$\Delta_B = -\frac{WL^3}{3EI} - \frac{WL^4}{8EI} \quad (\text{Downward deflection})$$

Problem 5.

Using the moment area method, determine the slope and deflection at B of the cantilever beam as shown in Figure 8. The beam is subjected to uniformly distributed load over entire length and point load at the free end.

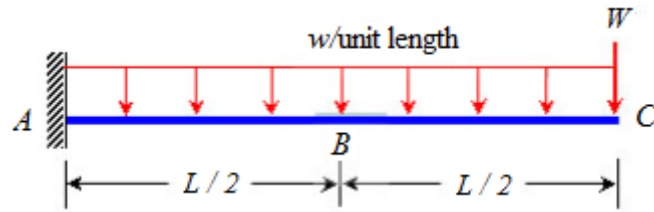

Figure 8

Solution.

Determine the support reactions,

Sum of the vertical forces, $\Sigma V = 0$; $R_A = W$

Instead of drawing composite M/EI diagram, it is convenient to draw M/EI diagrams in parts, one each for point load and uniformly distributed load.

Bending moment about A due to point load W, $M_{A1} = -WL$

Bending moment about B due to point load W, $M_{B1} = -WL$

Bending moment about A due to *udl*, $M_{A2} = -wL \frac{L}{2} = -\frac{wL^2}{2}$

Bending moment about B due to *udl*, $M_{B2} = -\frac{wL}{2} \frac{L}{4} = -\frac{wL^2}{8}$

Before applying moment-area theorems, divide the M/EI diagrams into three parts as shown.

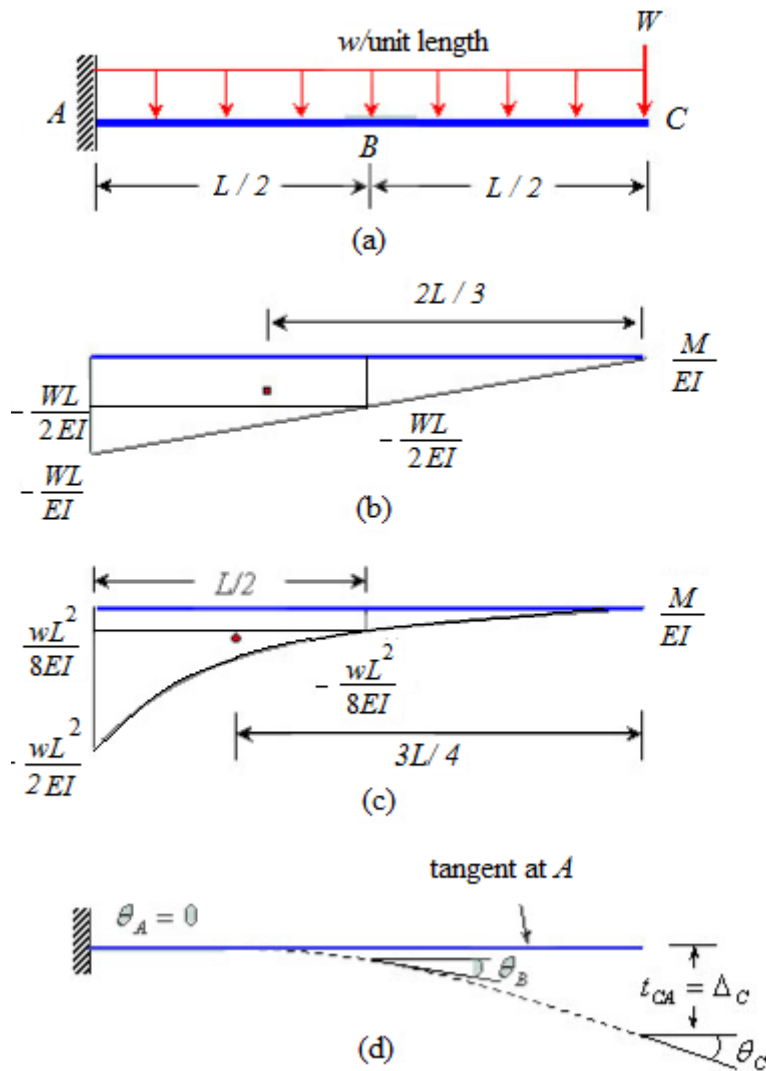

Figure 9

Applying first theorem of moment-area

The change in slope between the tangents drawn at two points \$A\$ and \$B\$ on the elastic curve which in this case is the slope at point \$B\$.

Total slope at \$B\$ = Slope due to point load + Slope due to \$udl\$

Slope at \$B\$ on account of point load,

$$\theta_{B1} = \text{Area of the } M/EI \text{ diagram between } A \text{ and } B$$

$$\theta_{B1} = A_1 + A_2$$

$$\theta_{B1} = \frac{1}{2} \times \frac{L}{2} \times \left\{ -\frac{WL}{EI} - \left(-\frac{WL}{2EI} \right) \right\} + \left(\frac{L}{2} \times -\frac{WL}{2EI} \right)$$

$$\theta_{B1} = -\frac{WL^2}{8EI} - \frac{WL^2}{4EI}$$

$$\theta_{B1} = -\frac{3WL^2}{8EI} \quad (\text{Clockwise rotation})$$

Slope at on account of \$udl\$,

$$\theta_{B2} = A'_1 + A'_2$$

$$\theta_{B2} = \frac{1}{3} \frac{L}{2} \times \left\{ -\frac{wL^2}{2EI} - \left(-\frac{wL^2}{8EI} \right) \right\} + \left(\frac{L}{2} \times -\frac{wL^2}{8EI} \right)$$

$$\theta_{B2} = \frac{L}{6} \times \left\{ -\frac{3wL^2}{8EI} \right\} + \left(-\frac{wL^3}{16EI} \right)$$

$$\theta_{B2} = -\frac{wL^3}{48EI} - \frac{wL^3}{16EI}$$

$$\theta_{B2} = -\frac{5wL^3}{48EI} \quad (\text{Clockwise rotation})$$

$$\text{Total Slope at } B, \quad \theta_B = \theta_{B1} + \theta_{B2} = -\frac{3WL^2}{8EI} - \frac{5wL^3}{48EI} \quad (\text{Clockwise rotation})$$

Applying second theorem of moment-area

The tangential deviation of point B with respect to the tangent drawn at point A which in this case is also the deflection at B with respect to the original beam position,

Total deflection at B = Deflection due to point load + Deflection due to udl

Deflection at B on account of point load,

Δ_{B1} = Moment of the area of M/EI diagram about point B

$$\Delta_{B1} = A_1 \bar{x}_1 + A_2 \bar{x}_2$$

$$\Delta_{B1} = \left(-\frac{WL^2}{8EI} \right) \times \frac{2}{3} \frac{L}{2} + \left(-\frac{WL^2}{4EI} \right) \times \frac{1}{2} \frac{L}{2}$$

$$\Delta_{B1} = \left(-\frac{WL^2}{8EI} \right) \times \left(\frac{L}{3} \right) + \left(-\frac{WL^2}{4EI} \right) \times \left(\frac{L}{4} \right)$$

$$\Delta_{B1} = \left(-\frac{WL^3}{24EI} \right) + \left(-\frac{WL^3}{16EI} \right)$$

$$\Delta_{B1} = -\frac{5WL^3}{48EI} \quad (\text{Downward deflection})$$

Deflection at B on account of udl ,

Δ_{B2} = Moment of the area of M/EI diagram about point B

$$\Delta_{B2} = A'_1 \bar{x}'_1 + A'_2 \bar{x}'_2$$

$$\Delta_{B2} = \frac{1}{3} \frac{L}{2} \times \left\{ -\frac{wL^2}{2EI} - \left(-\frac{wL^2}{8EI} \right) \right\} \times \frac{3}{4} \frac{L}{2} + \left(\frac{L}{2} \times -\frac{wL^2}{8EI} \right) \times \frac{1}{2} \frac{L}{2}$$

$$\Delta_{B2} = \frac{1}{3} \frac{L}{2} \times \left(-\frac{3wL^2}{8EI} \right) \times \frac{3}{4} \frac{L}{2} + \left(\frac{L}{2} \times -\frac{wL^2}{8EI} \right) \times \frac{1}{2} \frac{L}{2}$$

$$\Delta_{B2} = -\frac{wL^4}{128EI} - \frac{wL^4}{64EI}$$

$$\Delta_{B2} = -\frac{3wL^4}{128EI} \quad (\text{Downward deflection})$$

$$\text{Total deflection at } B, \quad \Delta_{B1} + \Delta_{B2} = -\frac{5WL^3}{48EI} - \frac{3wL^4}{128EI}$$

Problem 6.

Determine the slope and deflection at points B and C of the beam shown in the Figure. Take $E = 200 \text{ GPa}$ and $I = 250(10^6) \text{ mm}^4$

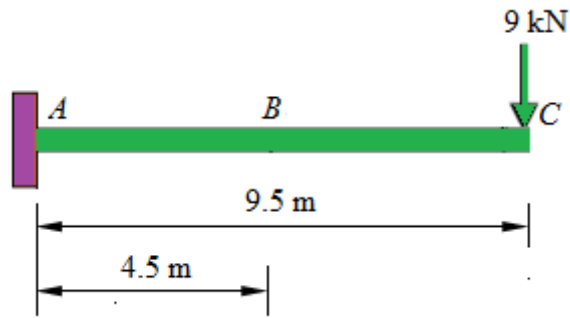
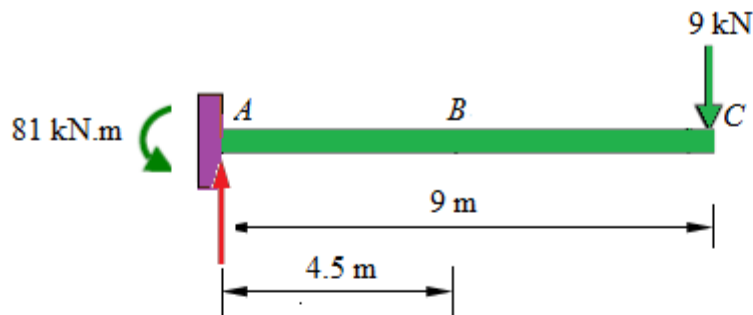
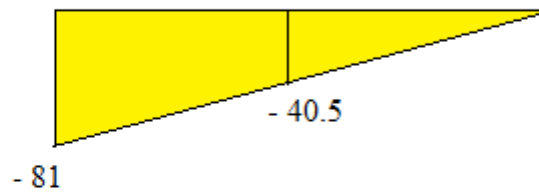

Figure 10

Solution.



(a) Beam with support reactions



(b) Bending moment diagram

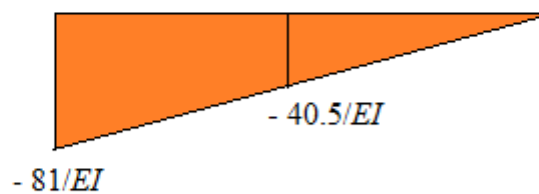

(c) M/EI Diagram

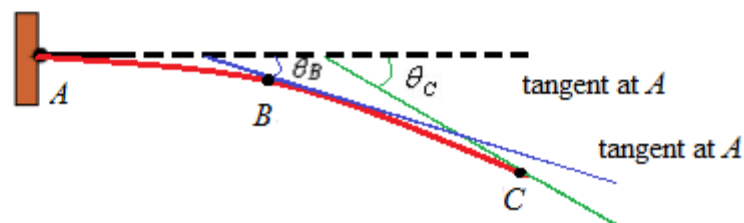

(d) Elastic curve

Figure 11

Determine the support reactions,
Sum of the vertical forces, $\Sigma V = 0$; $R_A = 9$

Bending moment at B, $M_B = -9 \times 4.5 = -40.5 \text{ kN.m}$
 Bending moment at A, $M_A = -9 \times 9 = -81 \text{ kN.m}$

Draw bending moment diagram as shown in the Figure xx(b) and M/EI diagram by dividing ordinate of the bending moment diagram by EI as shown in Figure xx(c).

Draw an exaggerated shape of the probable elastic curve as shown in Figure xx(d). It is known that the tangent drawn at fixed end A on the elastic curve would follow the original beam, hence slope at A, $\theta_A = 0$.

Before applying moment-area theorems, divide the M/EI diagram into two parts.

Area I: Trapezium

Area, $A_1 = \frac{1}{2} \times 4.5 \times \left(-\frac{81}{EI} - \frac{40.5}{EI} \right) = -\frac{273.375 \text{ kN.m}^2}{EI}$

Distance of the c.g of trapezium from B, $\bar{x}_1 = \frac{1}{3} \times 4.5 \times \left(\frac{\frac{40.5}{EI} + 2 \times \frac{81}{EI}}{\frac{40.5}{EI} + \frac{81}{EI}} \right) = 2.5 \text{ m}$

Area II: Full triangle

Area, $A_2 = \frac{1}{2} \times 9 \times \left(-\frac{81}{EI} \right) = -\frac{364.5 \text{ kN.m}^2}{EI}$

Distance of the c.g of Area I from C, $\bar{x}_2 = \frac{2}{3} \times 9 = 6 \text{ m}$

Applying first theorem of moment-area

The change in slope between the tangents drawn at two points A and B on the elastic curve,

$$\theta_B = \theta_{AB} = \text{Area of } M/EI \text{ diagram between A and B}$$

$$\begin{aligned} &= -\frac{273.375 \text{ kN.m}^2}{EI} \\ &= -\frac{273.375 \text{ kN.m}^2}{\left(200 \times 10^6 \frac{\text{kN}}{\text{m}^2} \right) \times 250 \times 10^{-6} \text{ m}^4} \\ &= -0.00547 \text{ rad} \quad (\text{clockwise}) \end{aligned}$$

The change in slope between the tangents drawn at two points A and C on the elastic curve,

$$\theta_C = \theta_{AC} = \text{Area of } M/EI \text{ diagram between A and C}$$

$$\begin{aligned} &= -\frac{364.5 \text{ kN.m}^2}{EI} \\ &= -\frac{364.5 \text{ kN.m}^2}{\left(200 \times 10^6 \frac{\text{kN}}{\text{m}^2} \right) \times (250 \times 10^{-6} \text{ m}^4)} \\ &= -0.00729 \text{ rad} \end{aligned}$$

Applying first theorem of moment-area

Deflection at B, $\Delta_B = \text{Moment of the area of } M/EI \text{ diagram between A and B about B}$

$$= -\frac{273.375 \text{ kN.m}^2}{EI} \times 2.5 \text{ m}$$

$$= - \frac{273.375 \text{ kN.m}^2}{\left(200 \times 10^6 \frac{\text{kN}}{\text{m}^2}\right) \times (250 \times 10^{-6} \text{ m}^4)} \times 2.5 \text{ m}$$

$$\Delta_B = -0.03167 \text{ m} = -13.67 \text{ mm} \downarrow$$

Deflection at C, $\Delta_C = \text{Moment of the area of } M/EI \text{ diagram between A and C about C}$

$$= - \frac{365.5 \text{ kN.m}^2}{EI} \times 2.5 \text{ m}$$

$$= - \frac{364.5 \text{ kN.m}^2}{\left(200 \times 10^6 \frac{\text{kN}}{\text{m}^2}\right) \times (250 \times 10^{-6} \text{ m}^4)} \times 6 \text{ m}$$

$$\Delta_C = -0.04374 \text{ m} = -43.74 \text{ mm} \downarrow$$

Problem 7.

Determine the slope and deflection at point B and C of the beam shown in the Figure xx.

Values of the moment of inertia of each segment are indicated in the figure. Take $E = 200$ Gpa.

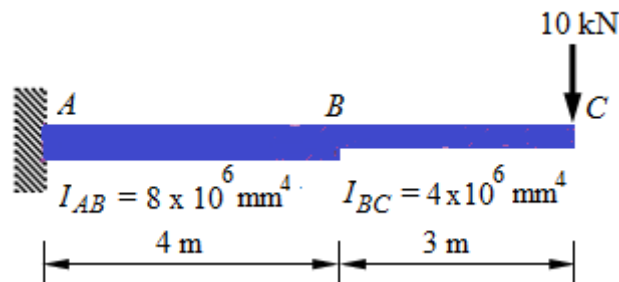

Figure 12

Solution:

Determine the support reactions,

Sum of the vertical forces, $\Sigma V = 0$; $R_A = 10 \text{ kN}$

Bending moment at B, $M_B = -10 \times 3 = -30 \text{ kN.m}$

Bending moment at A $M_A = -10 \times 7 = -70 \text{ kN.m}$

Moment of inertia of part AB, $I_{AB} = 8 \times 10^6 \text{ mm}^4$

Moment of inertia of part BC, $I_{BC} = 4 \times 10^6 \text{ mm}^4$

$I_{AB} = 2I_{BC} = 2I$, where $I = 4 \times 10^6 \text{ mm}^4$

Draw bending moment diagram as shown in the Figure xx(b) and M/EI diagram by dividing ordinate of the bending moment diagram by EI as shown in Figure xx(c).

Draw an exaggerated shape of the probable elastic curve as shown in Figure xx(d). It is known that the tangent drawn at fixed end A on the elastic curve would follow the original beam, hence slope at A, $\theta_A = 0$.

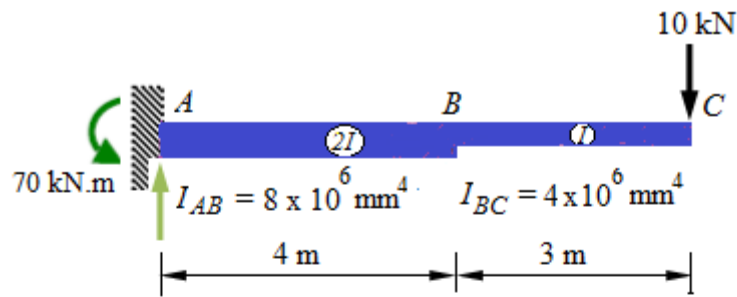

(a) Beam with upport reactions

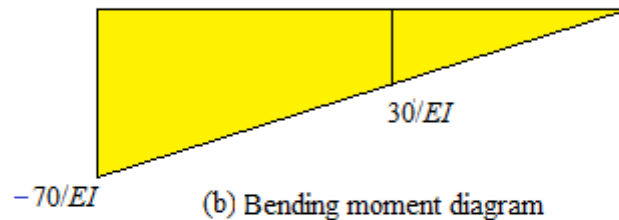

(b) Bending moment diagram

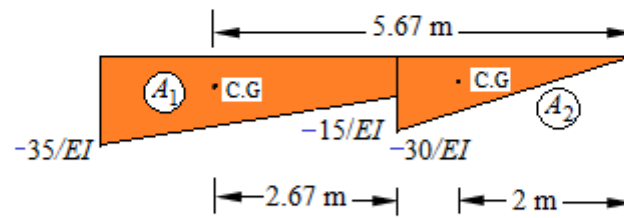

(c) M/EI Diagram

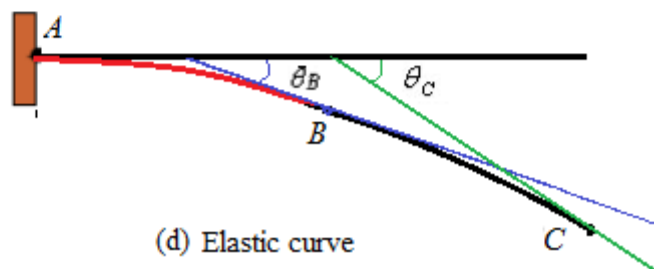

(d) Elastic curve

Figure 13

Before applying moment-area theorems, divide the M/EI diagram into two parts.

Area I: Trapezium

$$\text{Area, } A_1 = \frac{1}{2} \times 4 \times \left(-\frac{35}{EI} - \frac{15}{EI} \right) = -\frac{100 \text{ kN.m}^2}{EI}$$

$$\text{Distance of the c.g of trapezium from B, } \bar{x}_{1B} = \frac{1}{3} \times 4 \times \left(\frac{\frac{15}{EI} + 2 \times \frac{35}{EI}}{\frac{15}{EI} + \frac{35}{EI}} \right) = 2.67 \text{ m}$$

Distance of the c.g of trapezium from C, $\bar{x}_{1C} = 2.67 + 3 = 5.67 \text{ m}$

Area II: Triangle

$$\text{Area, } A_2 = \frac{1}{2} \times 3 \times \left(-\frac{30}{EI} \right) = -\frac{45 \text{ kN.m}^2}{EI}$$

$$\text{Distance of the c.g of Area I from C, } \bar{x}_{2C} = \frac{2}{3} \times 3 = 2 \text{ m}$$

Applying first theorem of moment-area

The change in slope between the tangents drawn at two points A and B on the elastic curve,

$$\theta_B = \theta_{AB} = \text{Area of } M/EI \text{ diagram between A and B}$$

$$\begin{aligned} &= -\frac{100 \text{ kN.m}^2}{EI} \\ &= -\frac{100 \text{ kN.m}^2}{\left(200 \times 10^6 \frac{\text{kN}}{\text{m}^2}\right) \times (4 \times 10^{-6} \text{ m}^4)} \\ &= -0.125 \text{ rad} \quad (\text{clockwise}) \end{aligned}$$

The change in slope between the tangents drawn at two points A and C on the elastic curve,

$$\theta_C = \theta_{AC} = \text{Area of } M/EI \text{ diagram between A and C}$$

$$\begin{aligned} &= A_1 + A_2 \\ &= -\frac{100 \text{ kN.m}^2}{EI} - \frac{45 \text{ kN.m}^2}{EI} \\ &= -\frac{145 \text{ kN.m}^2}{\left(200 \times 10^6 \frac{\text{kN}}{\text{m}^2}\right) \times (4 \times 10^{-6} \text{ m}^4)} \\ &= -0.18125 \text{ rad} \end{aligned}$$

Applying first theorem of moment-area

Deflection at B, $\Delta_B = \text{Moment of the area of } M/EI \text{ diagram between A and B about B}$

$$\begin{aligned} &= -\frac{100 \text{ kN.m}^2}{EI} \times 2.67 \text{ m} \\ &= -\frac{100 \text{ kN.m}^2}{\left(200 \times 10^6 \frac{\text{kN}}{\text{m}^2}\right) \times (4 \times 10^{-6} \text{ m}^4)} \times 2.67 \text{ m} \end{aligned}$$

$$\Delta_B = -0.334625 \text{ m} = -334.625 \text{ mm} \quad \downarrow$$

Deflection at C, $\Delta_C = \text{Moment of the area of } M/EI \text{ diagram between A and C about C}$

$$\begin{aligned} &= A_1 \times \bar{x}_{1C} + A_2 \times \bar{x}_{2C} \\ &= -\frac{100 \text{ kN.m}^2}{EI} \times 5.67 \text{ m} - \frac{45 \text{ kN.m}^2}{EI} \times 2 \text{ m} \\ &= -\frac{657 \text{ kN.m}^3}{\left(200 \times 10^6 \frac{\text{kN}}{\text{m}^2}\right) \times (4 \times 10^{-6} \text{ m}^4)} \end{aligned}$$

$$\Delta_C = -0.82125 \text{ m} = -821.25 \text{ mm} \quad \downarrow$$

Problem 8.

Determine the slope and deflection at point B and C of the beam shown in the Figure xx.

Values of the moment of inertia of each segment are indicated in the figure. Take E = 200

Gpa.

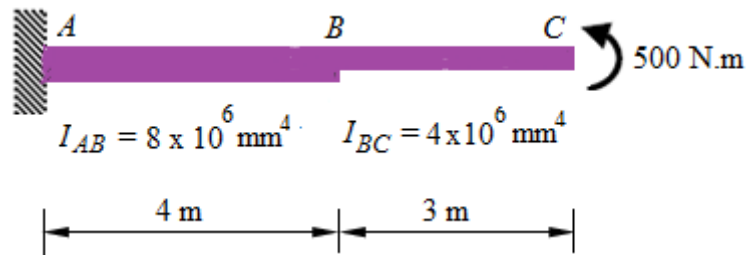

Figure 14

Solution:

Calculation of bending moment:

Bending moment throughout the beam is same and equal to 500 N.m

Moment of inertia of part AB, $I_{AB} = 8 \times 10^6 \text{ mm}^4$

Moment of inertia of part BC, $I_{BC} = 4 \times 10^6 \text{ mm}^4$

$I_{AB} = 2I_{BC} = 2I$, where $I = 4 \times 10^6 \text{ mm}^4$

Draw bending moment diagram as shown in the Figure xx(b) and M/EI diagram by dividing ordinate of the bending moment diagram by EI as shown in Figure xx(c).

Draw an exaggerated shape of the probable elastic curve as shown in Figure xx(d). It is known that the tangent drawn at fixed end A on the elastic curve would follow the original beam, hence slope at A, $\theta_A = 0$.

Before applying moment-area theorems, divide the M/EI diagram into two parts.

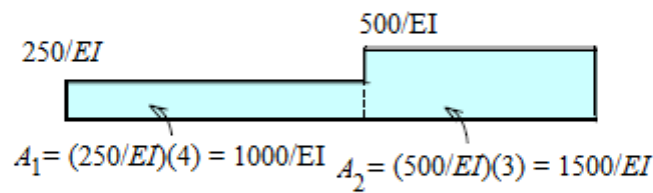
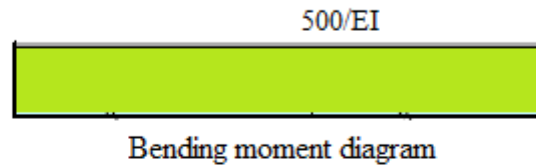
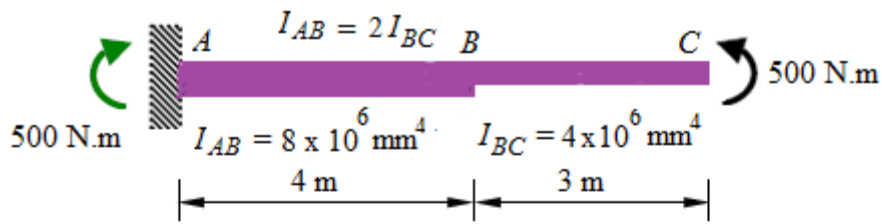

M/EI Diagram

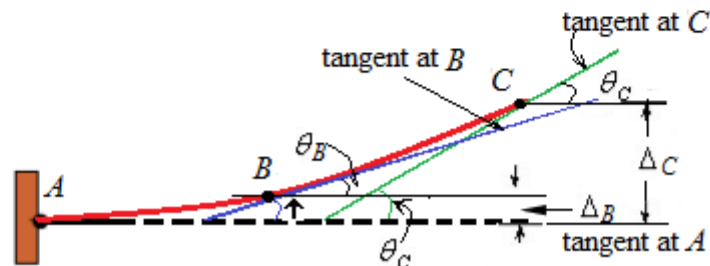

(d) Elastic curve

Figure 15

Area I: Trapezium

Area,
$$A_1 = 4 \times \frac{250}{EI} = -\frac{1000 N.m^2}{EI}$$

Distance of the c.g of trapezium from B, $\bar{x}_{1B} = 2m$

Distance of the c.g of trapezium from C, $\bar{x}_{1C} = 2 + 3 = 5m$

Area II: Triangle

Area,
$$A_2 = 3 \times \frac{500}{EI} = \frac{1500 N.m^2}{EI}$$

Distance of the c.g of Area I from C, $\bar{x}_{2C} = 1.5m$

Applying first theorem of moment-area

The change in slope between the tangents drawn at two points A and B on the elastic curve,

$$\theta_B = \theta_{AB} = \text{Area of } M/EI \text{ diagram between } A \text{ and } B$$

$$= -\frac{1000 N.m^2}{EI}$$

$$= -\frac{1000 N.m^2}{\left(200 \times 10^9 \frac{N}{m^2}\right) \times \left(4 \times 10^{-6} m^4\right)}$$

$$= -0.00125 \text{ rad} \quad (\text{clockwise})$$

The change in slope between the tangents drawn at two points A and C on the elastic curve,

$$\theta_C = \theta_{AC} = \text{Area of } M/EI \text{ diagram between A and C}$$

$$\begin{aligned} &= A_1 + A_2 \\ &= \frac{1000 N.m^2}{EI} + \frac{1500 N.m^2}{EI} \\ &= \frac{2500 N.m^2}{\left(200 \times 10^6 \frac{N}{m^2}\right) \times \left(4 \times 10^{-6} m^4\right)} \\ &= 0.003125 \text{ rad} \quad (\text{anticlockwise}) \end{aligned}$$

Applying second theorem of moment-area

Deflection at B, $\Delta_B = \text{Moment of the area of } M/EI \text{ diagram between A and B about B}$

$$\begin{aligned} &= \frac{1000 N.m^2}{EI} \times 2m \\ &= \frac{1000 N.m^2}{\left(200 \times 10^9 \frac{N}{m^2}\right) \times \left(4 \times 10^{-6} m^4\right)} \times 2m \\ \Delta_B &= 0.0025 m = 2.5 \text{ mm} \quad \uparrow \end{aligned}$$

Deflection at C, $\Delta_C = \text{Moment of the area of } M/EI \text{ diagram between A and C about C}$

$$\begin{aligned} &= A_1 \times \bar{x}_{1C} + A_2 \times \bar{x}_{2C} \\ &= \frac{1000 N.m^2}{EI} \times 5m + \frac{1500 N.m^2}{EI} \times 1.5m \\ &= \frac{7250 N.m^3}{\left(200 \times 10^9 \frac{N}{m^2}\right) \times \left(4 \times 10^{-6} m^4\right)} \\ \Delta_C &= 0.0090625 m = 9.0625 \text{ mm} \quad \uparrow \end{aligned}$$

Section II: Simply supported beam

Problem 9.

Determine the slope and deflection at point C of the beam shown in the Figure xx. Take $E = 200 \text{ Gpa}$ and $I = 60 \times 10^6 \text{ mm}^4$.

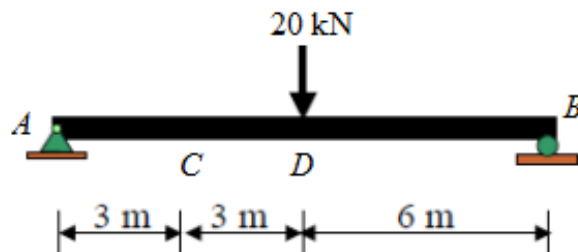

Figure 16

Solution.

Determine the support reaction,

The simply supported beam is symmetrically loaded. Hence the reactions at both ends are equal and 10 kN each.

So, the reaction at A, $R_A = 10 \text{ kN}$ and reaction at B, $R_B = 10 \text{ kN}$

Calculation of bending moment:

Considering from left hand side, bending moment at C, $M_C = 10 \times 3 = 30 \text{ kN.m}$

Bending moment at D, $M_D = 10 \times 6 = 60 \text{ kN.m}$

Now, draw the M/EI diagram. As the beam has uniform flexural rigidity, the shape of the M/EI diagram would be the same as that of the bending moment diagram. Only the ordinates would be reduced by $1/EI$.

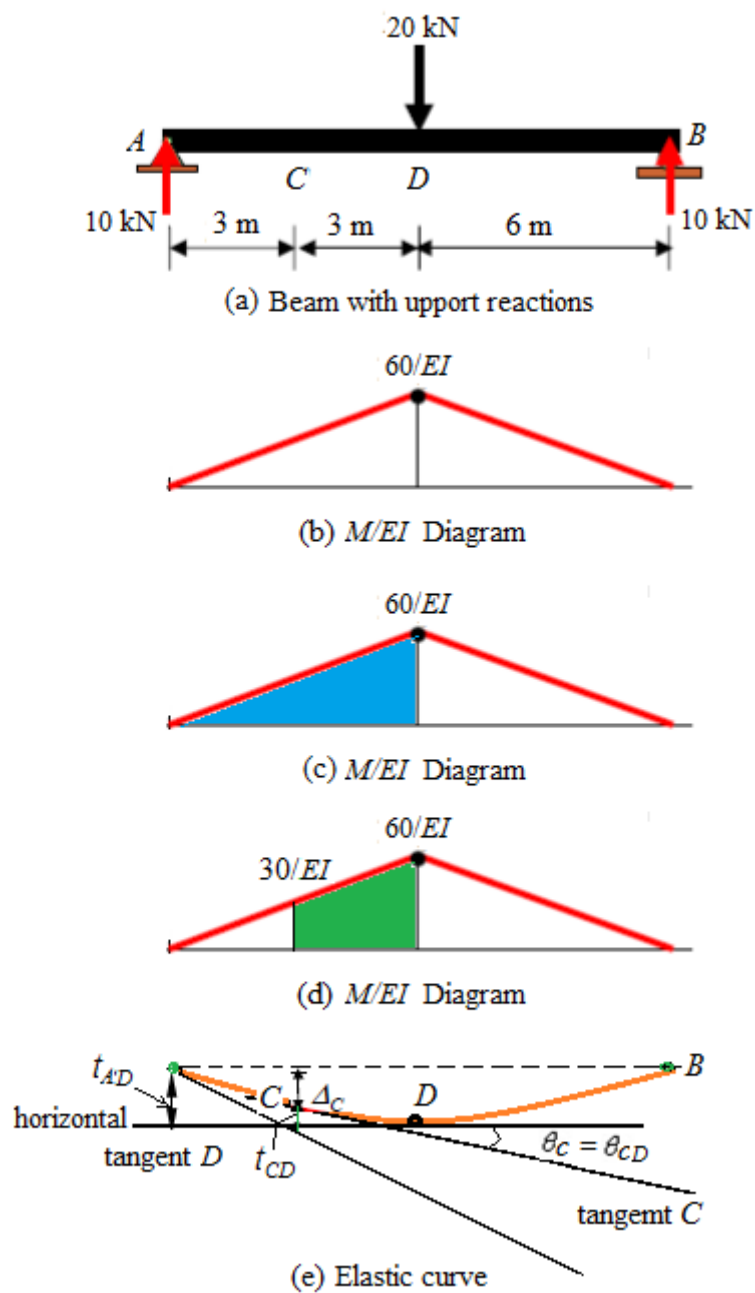

Figure 17

Draw an exaggerated shape of the probable elastic curve as shown in Figure 17 (d). Due to symmetry, the deflection at the centre of the beam would be maximum and hence the slope at D , $\theta_D = 0$, i.e., the tangent drawn at D on the elastic curve would be horizontal and parallel to the original beam without loading. Figure 17 (d) shows the elastic curve with tangents drawn at required points to solve the problem.

The tangential deviation at C with respect to the tangent to the elastic curve at D ,

$$t_{CD} = \text{Moment of Area of } M/EI \text{ diagram between } D \text{ and } C \\ \text{as shown in Figure 18(d) about } C$$

$$= \frac{1}{2} \times 3 \left(\frac{30}{EI} + \frac{60}{EI} \right) \times \frac{3}{3} \left(\frac{\frac{30}{EI} + \frac{2 \times 60}{EI}}{\frac{30}{EI} + \frac{60}{EI}} \right) \\ = \frac{225 \text{ kN.m}^3}{EI}$$

The tangential deviation at A with respect to the tangent to the elastic curve at D ,

$$t_{AD} = \text{Moment of Area of } M/EI \text{ diagram between } D \text{ and } A \\ \text{as shown in Figure 18(d) about } A$$

$$= \frac{1}{2} \times 6 \times \frac{60}{EI} \times \frac{2 \times 6}{3} \\ = \frac{720 \text{ kN.m}^3}{EI}$$

Deflection at C ,

$$\Delta_C = t_{AD} - t_{CD} = \frac{720}{EI} - \frac{225}{EI} \\ = \frac{495 \text{ kN.m}^3}{EI} \\ = \frac{495 \times 10^3 \text{ N.m}^3}{\left(200 \times 10^9 \frac{\text{N}}{\text{m}^2} \right) \times \left(60 \times 10^6 \times 10^{-12} \text{ m}^4 \right)} \\ = 0.04125 \text{ m} \\ = 41.25 \text{ mm} \downarrow$$

Slope at C can be obtained by applying first theorem of moment area between C and D

$$\theta_{DC} = \theta_C - \theta_D = \frac{1}{2} \times 3 \left(\frac{30}{EI} + \frac{60}{EI} \right) \\ = \frac{135 \text{ kN.m}^2}{EI} \\ = \frac{135 \times 10^3 \text{ N.m}^2}{\left(200 \times 10^9 \frac{\text{N}}{\text{m}^2} \right) \times \left(60 \times 10^6 \times 10^{-12} \text{ m}^4 \right)} \\ = 0.01125 \text{ mm} \quad (\text{anticlockwise})$$

Problem. 10

Determine the slope and deflection at points C of the beam shown in the figure. Take $E = 200$ GPa and $I = 60(10^6)$ mm⁴

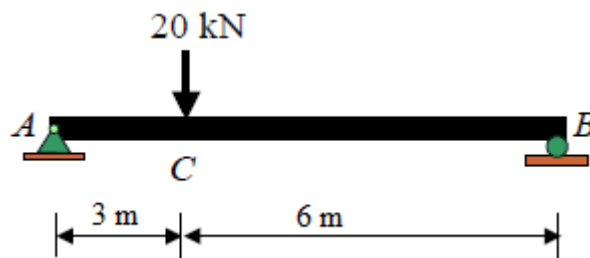

Figure 18

Solution.

Determine the support reaction,

$$\sum V = 0, \quad R_A + R_B = 20 \quad (1)$$

Taking moment about A, $R_A \times 12 = 20 \times 9$

$$R_A = 15 \text{ kN}$$

Substituting the value of R_A in Eq. (1), we get

$$R_B = 5 \text{ kN}$$

Calculation of bending moment,

Considering from left hand side of the beam,

Bending moment at C , $M_C = 5 \times 3 = 15 \text{ kN}$

Now, draw the M/EI diagram. As the beam has uniform flexural rigidity, the shape of the M/EI diagram would be the same as that of the bending moment diagram. Only the ordinates would be reduced by $1/EI$.

Draw an exaggerated shape of the probable elastic curve as shown in Figure 19 (d).

Point of zero slope is not known as the structure has neither a fixed support nor a symmetric loading condition. Hence, the geometry of the deflected shape as well as the moment area theorems have to be used to solve the problem.

The tangential deviation at C with respect to the tangent to the elastic curve at A ,

$$t_{CA} = \text{Moment of Area of } M/EI \text{ diagram between A and C} \\ \text{as shown in Figure 18(c) about C}$$

$$= \frac{1}{2} \times 3 \times \frac{45}{EI} \times \frac{3}{3}$$

$$= \frac{135}{2EI}$$

The tangential deviation at B with respect to the tangent to the elastic curve at A,

$$t_{BA} = \text{Moment of Area of } M/EI \text{ diagram between A and B} \\ \text{as shown in Figure 18(d) about B}$$

$$= \frac{1}{2} \times 12 \times \frac{45}{EI} \times \frac{12+9}{3} \\ = \frac{1890}{EI}$$

The tangential deviation at B with respect to the tangent to the elastic curve at C,

$$t_{BC} = \text{Moment of Area of } M/EI \text{ diagram between C and B} \\ \text{as shown in Figure 18(e) about B}$$

$$= \frac{1}{2} \times 9 \times \frac{45}{EI} \times \frac{2 \times 9}{3} \\ = \frac{1215}{EI}$$

From the geometry of the elastic curve,

$$\frac{t_{B/A}}{\Delta'} = \frac{3}{12}$$

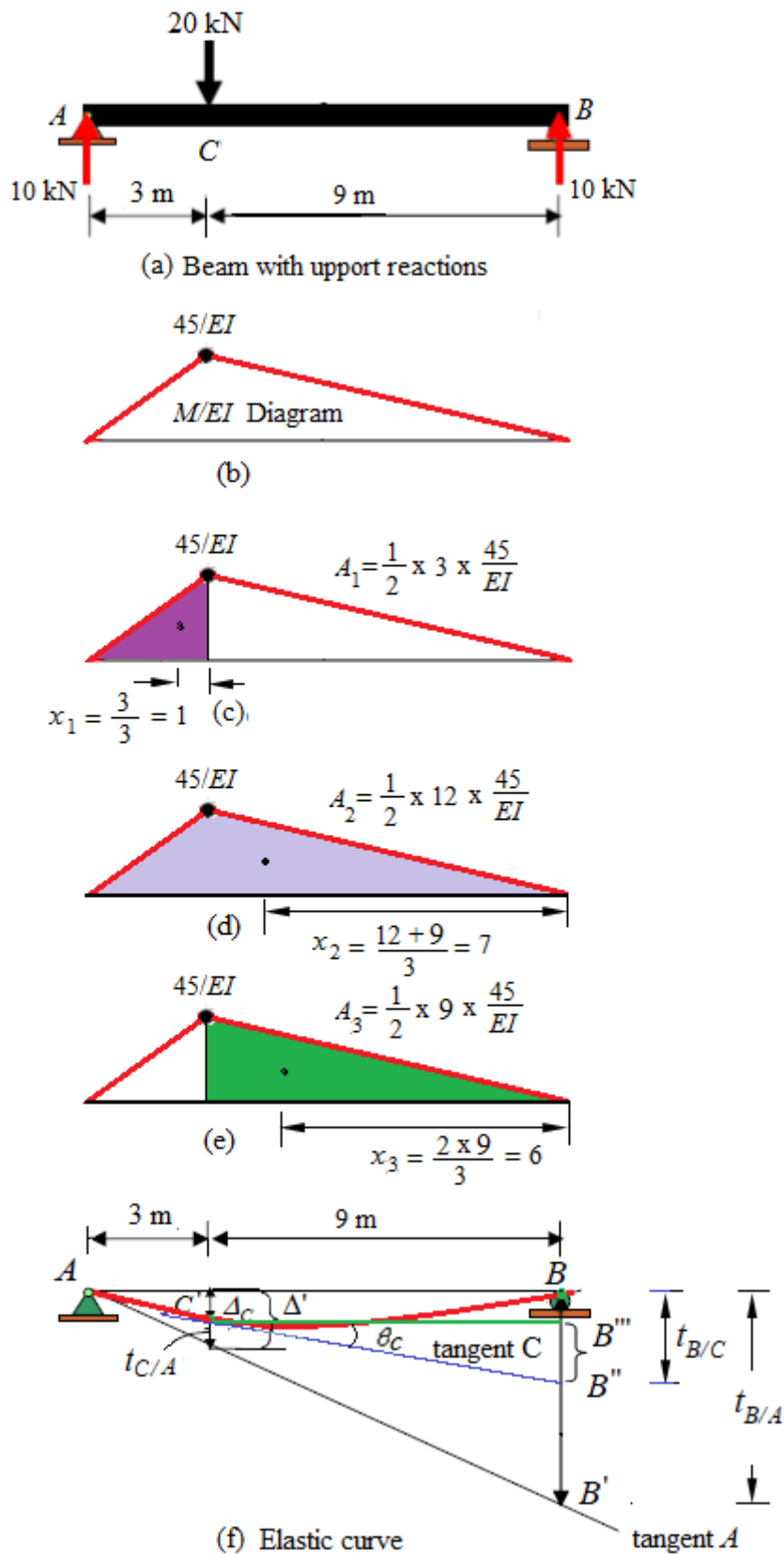

Figure 19

$$\Delta' = \frac{t_{B/A}}{4} = \frac{1890}{4EI}$$

$$= \frac{472.5}{EI}$$

So, $\Delta_C = \Delta' - t_{C/A} = \frac{472.5}{EI}$

$$= \frac{472.5}{EI} - \frac{135}{EI}$$

$$= \frac{337.5}{EI}$$

$$B''B''' = BB'' - BB'''$$

$$= t_{B/C} - \Delta_C$$

$$= \frac{1215}{EI} - \frac{337.5}{EI}$$

$$= \frac{877.5}{EI}$$

In the triangle $C'B''B'''$, $\theta_C = \frac{B''B'''}{C'B'''} = \frac{\frac{877.5}{EI}}{9} = \frac{877.5}{9EI}$

$$= \frac{877.5 \text{ kN.m}^3}{9\text{m} \times 200 \times 10^6 \frac{\text{kN}}{\text{m}^2} \times 60 \times 10^6 \times 10^{-12} \text{m}^4}$$

$$= 0.008125 \text{ radian (clockwise)}$$

Deflection at C, $\Delta_C = \frac{337.5 \text{ kN.m}^3}{EI}$

$$= \frac{337.5 \text{ kN.m}^3}{200 \times 10^6 \frac{\text{kN}}{\text{m}^2} \times 50 \times 10^6 \times 10^{-12} \text{m}^4}$$

$$= 0.03375 \text{ m}$$

$$= 33.75 \text{ mm } \downarrow$$

CHAPTER-3

FIXED BEAMS

INTRODUCTION

A beam, which is built-in/fixed at its two supports, is called a fully constrained beam or a fixed beam. As the beam is fixed at its two supports, the slope of the elastic curve of the beam at its two ends, even after loading will be zero. Thus a fixed beam AB may be looked upon as a simply supported beam, subjected to end moments M_A and M_B , such that the slopes at two supports are zero. This is only possible, if the magnitude and directions of the restraining moments M_A and M_B are equal and opposite to that of the bending moments under a given system of loading.

ADVANTAGES OF FIXED BEAM

A fixed beam has the following advantages over a simply supported beam.

- a) The beam is stiffer, stronger and more stable.
- b) The slope at both the ends is zero.
- c) The fixing moments are developed at the two ends, whose effect is to reduce the maximum bending moment at the centre of the beam.
- d) The deflection of a beam, at its centre is very much reduced.

Fixing Moments of a Fixed Beam Carrying a Central Point Load

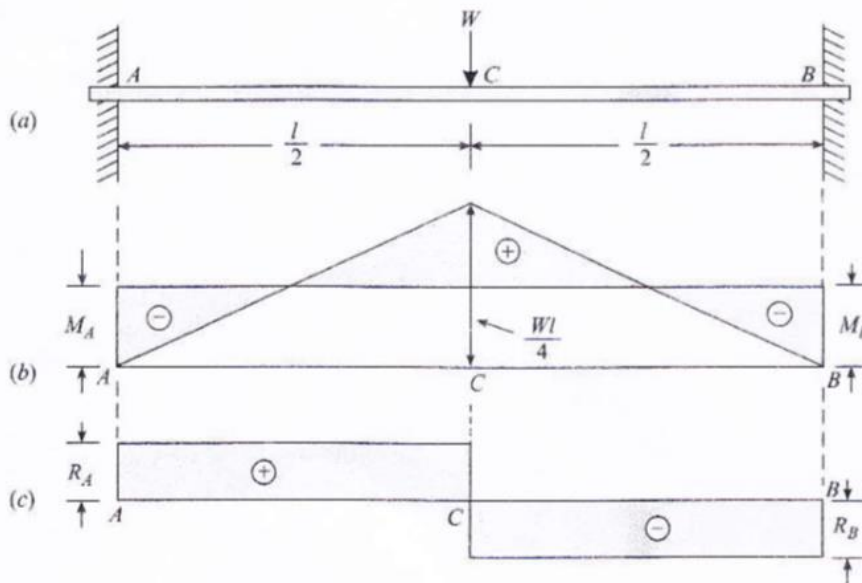

Fig. 3.1

Let us consider a beam AB of length l fixed at A and B and carrying a central point load W as shown in Fig. 3.1(a)

(i) *Bending moment diagram*

Let M_A = Fixing moment at A and

M_B = Fixing moment at B.

Since the beam is symmetrical, therefore M_A and M_B will also be equal.

Moreover, the bending moment diagram due to fixing moments M_A and M_B will be a rectangle as shown in Fig. 3.1(b)

We know that μ – diagram i.e., bending moment diagram due to central point load will be a triangle with the central ordinate equal to $\frac{wl}{4}$ as shown in Fig. 3.1(b)

Equating the areas of the two diagrams,

$$M_A \cdot l = -\frac{1}{2} \cdot l \cdot \frac{wl}{4} = -\frac{wl^2}{8}$$

$$M_A = -\frac{Wl}{8}$$

$$M_B = -\frac{WL}{8}$$

Complete the bending moment diagram is as shown in Fig. 3.1(b)

Shear force diagram

Let R_A = Reaction at A and

R_B = Reaction at B

Equating clockwise moments and anticlockwise moments about A,

$$R_A \cdot l + M_A = M_B + Wx \frac{l}{2}$$

$$\therefore R_B = \frac{W}{2} \quad \dots (\because M_A = M_B)$$

$$R_A = \frac{W}{2}$$

The complete the S.F. diagram is as shown in Fig. 3.1(c)

Example.1 A fixed beam AB, 4 metres long, is carrying a central point load of 3 tonnes. Determine the fixing moments.

Solution. Given: length (l) = 4m; Central point load (W) = 3kN and flexural rigidity (EI) = $5 \times 10^3 \text{ kN-m}^2$.

Fixing moments

We know that fixing moment at A,

$$M_A = -\frac{Wl}{8} = -\frac{3 \times 4}{8} = -1.5 \text{ kNm}$$

Similarly, fixing moment at B,

$$M_B = -\frac{Wl}{8} = -\frac{3 \times 4}{8} = -1.5 \text{ kNm}$$

Fixing Moments of a Fixed Beam Carrying a Uniformly Distributed Load

Consider a beam AB of length l fixed at A and B and carrying a uniformly distributed load w per unit length over the entire span as shown in Fig. 3.2(a).

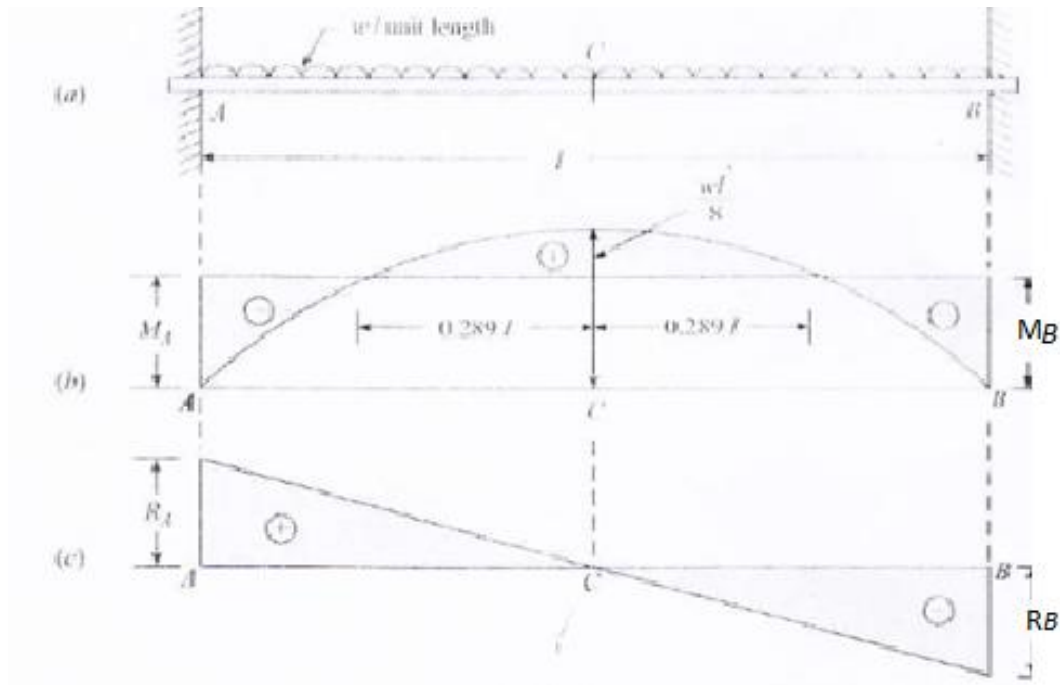

Fig. 3.2

(i) *Bending moment diagram*

Let M_A = Fixing moment at A and

M_B = Fixing moment at B.

Since the beam is symmetrical, M_A and M_B are equal. Moreover, the μ' -**diagram** (i.e. **Fixed end moment diagram**) will be a rectangle, as shown in fig. We know that the μ -**diagram** (i.e. **Bending moment diagram**) will be a parabola with the central ordinate equal to $\frac{wl^2}{8}$ as shown in Fig. 3.2(b).

Now equating the areas of the two diagrams,

$$M_A \cdot l = -\frac{2}{3} \cdot l \cdot \frac{wl^2}{8} = -\frac{wl^3}{12}$$

$$M_A = -\frac{wl^2}{12} \quad \dots \text{(By symmetry)}$$

$$M_B = -\frac{wl^2}{12}$$

We know that maximum positive bending moment at the centre of the beam (neglecting fixing moments)

$$= \frac{wl^2}{8}$$

Net positive bending moment at the centre of the beam

$$= \frac{wl^2}{8} - \frac{wl^2}{12} = \frac{wl^2}{24}$$

Now complete the bending moment diagram as shown in fig Fig. 3.2(b)

(ii) *Shear force diagram*

Let R_A = Reaction at A, and

R_B = Reaction at B.

By taking moments about A,

$$R_B \times l + M_A - M_B - w \times l \times \frac{l}{2} = 0$$

$$\Rightarrow R_B = \frac{wl}{2} \quad \dots (\because M_A = M_B)$$

but, $R_A + R_B - wl = 0$

$$\Rightarrow R_A = \frac{wl}{2}$$

The complete shear force diagram is as shown in Fig. 3.2 (c)

Example. 2.

A fixed beam AB of span 6 m is carrying a uniformly distributed load of 4kN/m over the left half of the span. Find the fixing moments and support reactions.

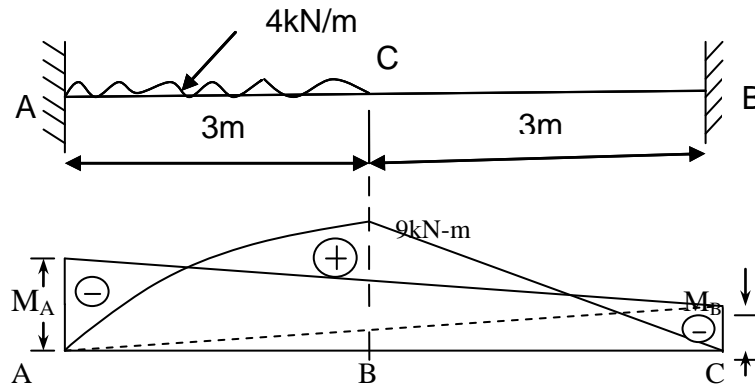

Fig. 3.3

Solution. Given: Span (l) = 6m; uniformly distributed load (W) = 4kN/m and loaded portion (l_1) = 3m.

Fixing moments

Let, M_A = Fixing moment at A and

M_B = Fixing moment at B.

First of all, consider the beam AB on a simply supported. Taking moments about A,

$$R_B \times 6 = 4 \times 3 \times 1.5 = 18$$

$$\Rightarrow R_B = \frac{18}{6} = 3 \text{ kN}$$

$$R_A = 3 \times 4 - 3 = 9 \text{ kN}$$

We know that μ - diagram will be parabolic from A to C and triangular from C to B as shown in Fig3.3. The bending moment at C (treating the beam as a simply supported),

$$M_C = R_B \times 3 = 3 \times 3 = 9 \text{ kNm}$$

The bending moment at any section x in AC, at a distance x from A (treating the beam as a simply supported),

$$M_x = 9 \times x - 4x \times \frac{x}{2} = 9x - 2x^2$$

Area μ - diagram from A to B,

$$\begin{aligned}
 a &= \int_0^3 (9x - 2x^2) dx + \frac{1}{2} \times 9.0 \times 3 \\
 &= \left[\frac{9x^2}{2} - \frac{2x^3}{3} \right]_0^3 + 13.5 \\
 &= \frac{9 \times (3)^2}{2} - \frac{2 \times (3)^3}{3} + 13.5 = 36
 \end{aligned}$$

And area of μ' – diagram, $a' = (M_A + M_B) \times \frac{6}{2} = 3(M_A + M_B)$

We know that $a' = -a$

$$3(M_A + M_B) = -36$$

$$\text{or } (M_A + M_B) = -\frac{36}{3} = -12 \dots \quad \text{(i)}$$

Moment of μ – diagram area about A (by splitting up the diagram into AC and CB),

$$\begin{aligned}
 a\bar{x} &= \int_0^3 (9x^2 - 2x^3) dx + \frac{1}{2} \times 9 \times 3 \times 4 \\
 a\bar{x} &= \left[\frac{9x^3}{3} - \frac{2x^4}{4} \right]_0^3 + 54 \\
 &= \left[\frac{9 \times (3)^3}{3} - \frac{2 \times (3)^4}{4} \right] + 54 = 94.5
 \end{aligned}$$

And moment of μ' – diagram area about A (by splitting up the trapezium into two triangles) as shown in fig.

$$\begin{aligned}
 a'\bar{x}' &= \left(M_A \times \frac{6}{2} \times \frac{6}{3} \right) + M_B \times \frac{6}{2} \times \frac{2 \times 6}{3} \\
 &= 6M_A + 12M_B = 6(M_A + 2M_B)
 \end{aligned}$$

$$a'\bar{x}' = -a\bar{x}$$

We know that $6(M_A + 2M_B) = -94.5 \dots \text{(ii)}$

$$M_A + 2M_B = -\frac{94.5}{6} = -15.75$$

Solving the equation (i) and (ii),

$$M_A = -8.25 \text{ kNm}$$

$$M_B = -3.75 \text{ kNm}$$

The bending moment diagram is as shown in Fig. 3.3

Support Reactions

Let, R_A = Reaction at A, and

R_B = Reaction at B.

Equating the clockwise moments and anticlockwise moments about A,

$$R_B \times 6 + 8.25 = (4 \times 3 \times 1.5) + 3.75 = 21.75$$

$$R_B = \frac{21.75 - 8.25}{6} = 2.25 \text{ kN}$$

$$R_A = 4 \times 3 - 2.25 = 9.75 \text{ kN}$$

Example.3 A beam AB of uniform section and 6m span is built-in at the ends. A uniformly distributed load of 3kN/m runs over the left half of the span and there is in addition a concentrated load of 4kN at right quarter as shown in fig. Determine the fixing moments at the ends, and the reactions. Sketch neatly the bending moment and shear force diagram marking thereon salient values.

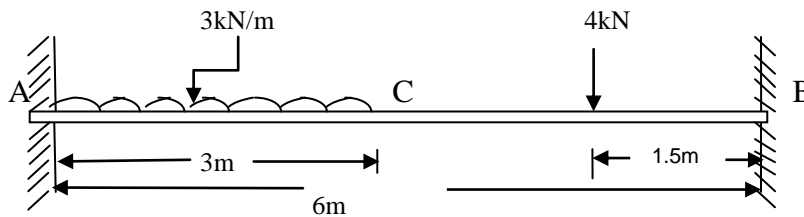

Fig. 3.4

Solution:

Given: Span (l) = 6m; Uniformly distributed load on AC (w) = 3kN/m ; Loaded portion (l_1) = 3m and concentrated load at D (W) = 4kN.

Fixing moment at the ends

Let, M_A = Fixing moment at A and

M_B = Fixing moment at B.

First of all, consider the beam AB on a simply supported. Taking moments about A,

$$R_B \times 6 = (3 \times 3 \times 1.5) + (4 \times 4.5) = 31.5$$

$$R_B = \frac{31.5}{6} = 5.25 \text{ kN}$$

$$R_A = (3 \times 3 + 4) - 5.25 = 7.75 \text{ kN}$$

We know that the μ – diagram will be parabolic from A to C, trapezoidal from C to D and triangular from D to B as shown in fig. The bending moment at D (treating the beam as a simply supported),

$$M_D = 5.25 \times 1.5 = 7.875 \text{ kNm}$$

$$M_C = 5.25 \times 3 - 4 \times 1.5 = 9.75 \text{ kNm}$$

The bending moment at any section X in AC, at a distance x from A (treating the beam as a simply supported),

$$M_x = 7.75x - 3x \frac{x}{2} = 7.75x - 1.5x^2$$

Area of μ – diagram from A to B,

$$\begin{aligned} a &= \int_0^3 (7.75x - 1.5x^2) dx + \left(\frac{1}{2} (9.75 + 7.875) \times 1.5 \right) + \left(\frac{1}{2} \times 7.875 \times 1.5 \right) \\ &= \left[\frac{7.75x^2}{2} - \frac{1.5x^3}{3} \right]_0^3 + 19.125 \\ &= \frac{7.75 \times (3)^2}{2} - \frac{1.5 \times (3)^3}{3} + 19.125 = 40.5 \end{aligned}$$

$$\text{And area of } \mu' \text{ – diagram, } a' = (M_A + M_B) x \frac{6}{2} = 3(M_A + M_B)$$

We know that $a' = -a$

$$3(M_A + M_B) = -40.5 \quad \dots (\because a = 40.5)$$

$$\text{or } (M_A + M_B) = -13.5 \dots \text{(i)}$$

Moment of μ – diagram area about A

(by splitting up the diagram into AC, CD and DB),

$$\begin{aligned} a\bar{x} &= \int_0^3 (7.75x^2 - 1.5x^3) dx + \left(\frac{1}{2} \times 9.75 \times 1.5 \times 3.5 \right) + \left(\frac{1}{2} \times 7.875 \times 1.5 \times 4 \right) + \left(\frac{1}{2} \times 7.875 \times 1.5 \times 5 \right) \\ &= \left[\frac{7.75x^3}{3} - \frac{1.5x^4}{4} \right]_0^3 + 78.75 \\ &= \left[\frac{7.75 \times (3)^3}{3} - \frac{1.5 \times (3)^4}{4} \right] + 78.75 = 118.1 \end{aligned}$$

And moment of μ' -diagram area about A (by splitting up the trapezium into two triangles),

$$a'x' = \left(M_A x \frac{6}{2} x \frac{6}{3} \right) + \left(M_B x \frac{6}{2} x \frac{2x6}{3} \right)$$

$$= 6M_A + 12M_B = 6(M_A + 2M_B)$$

We know that $a'\bar{x}' = -a\bar{x}$

$$6(M_A + 2M_B) = -118.1$$

$$\text{or } M_A + 2M_B = -\frac{118.1}{6} = -19.7 \quad \dots \text{ (ii)}$$

Solving equations (i) and (ii), we get

$$M_A = -7.3 \text{ kNm and } M_B = -6.2 \text{ kNm}$$

The bending moment diagram is as shown in Fig. 3.5(a).

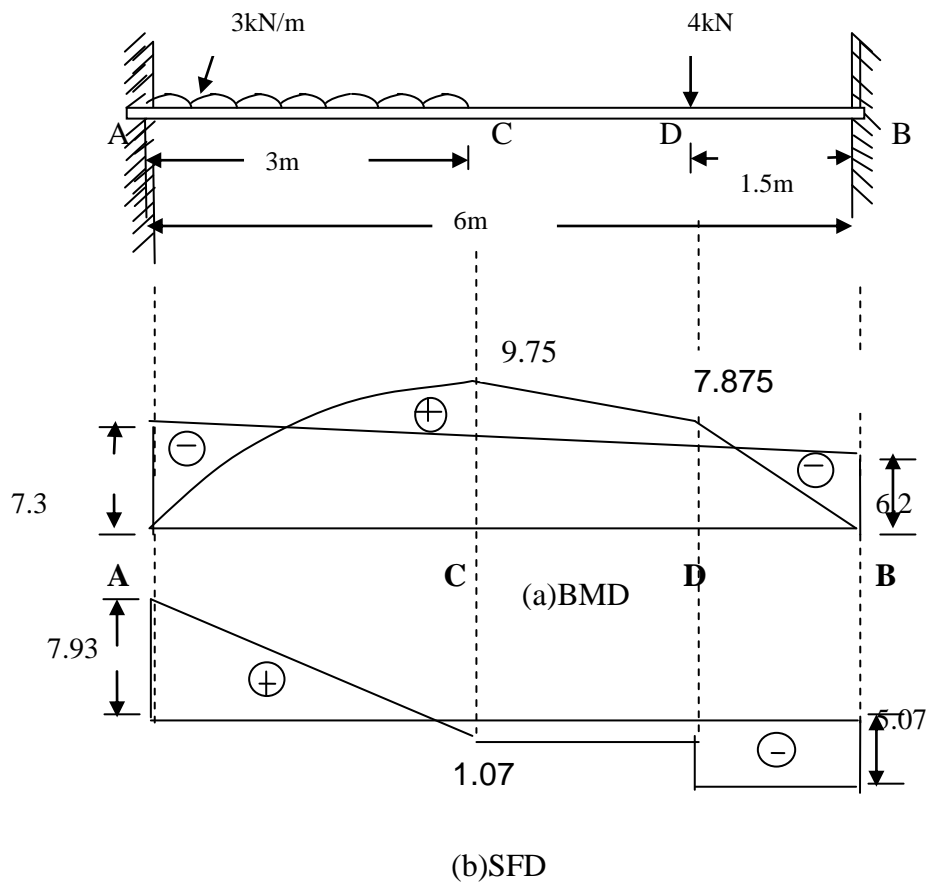

Fig. 3.5

Shear force diagram

Let R_A = Reaction at A, and

R_B = Reaction at B.

Equating the clockwise moments and anticlockwise moments about A,

$$R_B \times 6 + 7.3 = (3 \times 3 \times 1.5) + (4 \times 4.5) + 6.2 = 37.7$$

$$\therefore R_B = \frac{37.7 - 7.3}{6} = 5.07 \text{ kN}$$

And $R_A = (3 \times 3 + 4) - 5.07 = 7.93 \text{ kN}$

The shear force diagram is as shown in Fig. 3.5(b)

EXERCISES

1. Draw the BMD & SFD of a fixed beam of span 6m subjected to a *udl* of 10 kN/m for the full span and a point load of 25 kN at the centre.
2. Draw the BMD & SFD of a fixed beam of span 5m subjected to a *udl* of 20 kN/m for the central 2.5m of the span.
3. Draw the BMD & SFD of a fixed beam of span 4m subjected to two point loads of 20kN each acting at a distance of 1m from the supports.
4. Draw the BMD & SFD of a fixed beam of span 4m subjected to two point loads of 20kN each acting at a distance of 1m from the supports and a *udl* of 10 kN/m at the central 2m span.

CHAPTER-4

THE THREE-MOMENT EQUATION

4.0 Introduction:

Beams with more than one span are called *continuous beams*, as they “continue” over the intermediate supports. The beams shown in the Fig. 4.0 are continuous beams of four spans. The degrees of indeterminacy of the three beams as shown in the figure below [Fig. 4.0 (a), (b), (c)] are 3, 4, and 5 respectively.

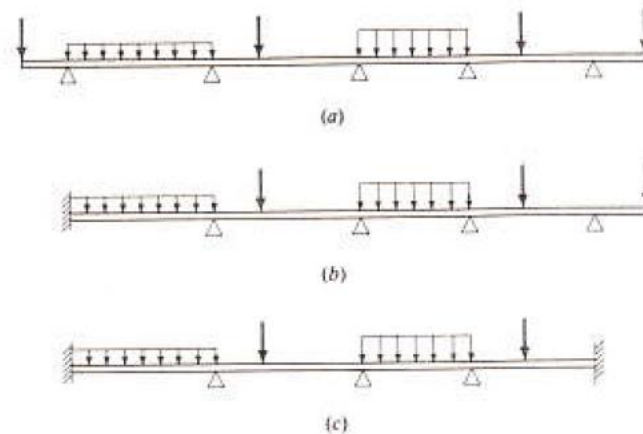

Fig. 4.0 Continuous beams

Continuous beams are very common as structural elements of bridge and frame structure buildings. A convenient approach to analyze such beams is to use statistically unknown bending moments at supports as redundant. For the unknown moment at a fixed support, the compatibility condition is that the slope there must be zero. For the unknown moment at the intermediate support, the compatibility condition is that the slope of the elastic curve at the right end of the span to the left of the support must be equal to the slope of the elastic curve at the left end of the span to the right of the support. In this way, each span can be considered as a simple beam with constant moment of inertia, acted upon by the loads on it and moments at both ends if there are any. Thus, the compatibility condition corresponding to the unknown bending moment at any intermediate support can be expressed in terms of the loads on the two adjacent spans and the bending moment at three successive supports, including the one before and the one after the support being considered. As this compatibility condition involves three bending moments at supports, it is called *three moment equation*. This *three moment equation* was first developed by Clapeyron in 1827.

4.1 Derivation of the Three-Moment Equation:

The three-moment equation expresses the relation between the bending moments at three successive supports of a continuous beam, subjected to loads applied on the two adjacent spans, with or without uneven settlements of the supports. This relation can be

derived on the basis of the *continuity* of the elastic curve over the middle support; that is, the slope of the elastic curve at the right end of the left span must be equal to the slope of the elastic curve at the left end of the right span.

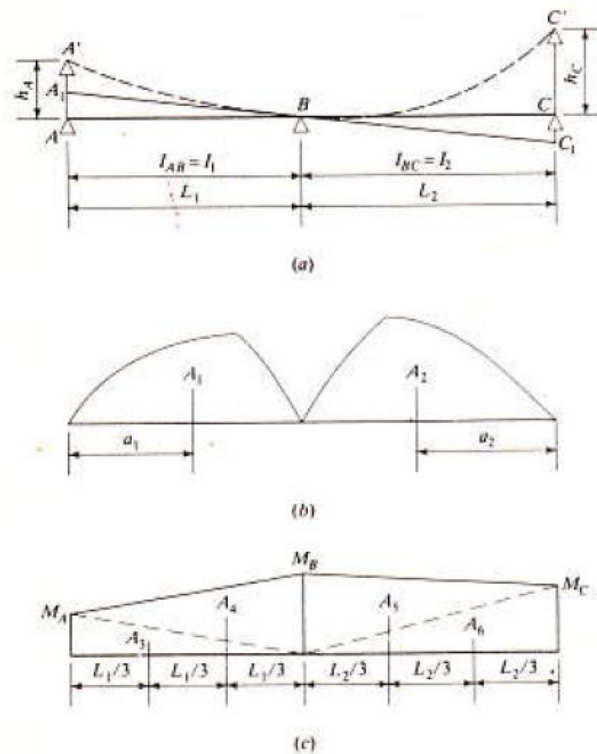

Fig. 4.1 Moment diagram of two adjacent spans of a continuous beam.

Let AB and BC in Fig. 4.1a be the two adjacent spans in an originally horizontal beam. Owing to uneven settlements, supports A and C are at higher elevations than support B by the amounts h_A and h_C , respectively; thus the elastic curve passes through points A' , B , and C' . Let M_A , M_B , and M_C be the bending moments at A , B , and C , these moments being positive if they cause compression in the upper parts of the beam.

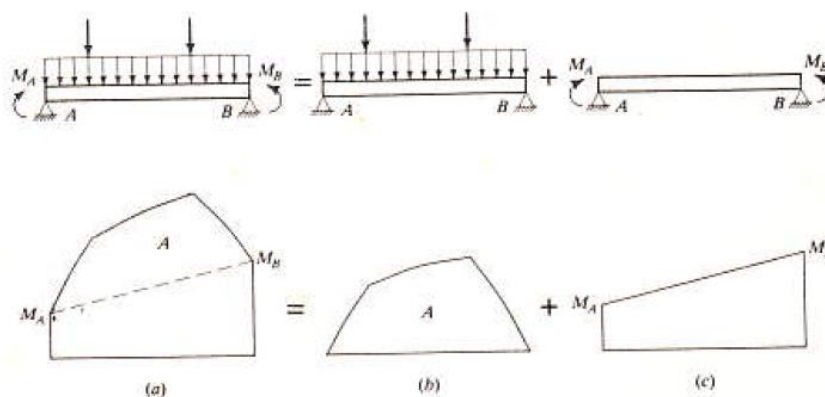

Fig. 4.2 Superposition of moment diagrams on a typical span.

Now consider Fig. 4.2, where the moment diagram on span AB is broken into two parts: Fig. 4.2b represents the moment diagram due to loads applied on AB when it is considered as a

simple beam, and Fig. 4.2c represents the moment diagram resulting from the moments M_A and M_B at the supports. By superposition, the entire moment diagram is shown in Fig. 4.2a. Returning to Fig. 4.1, note that the moment diagrams on spans AB and BC are each broken in to two parts: the parts A_1 and A_2 due to loads on the respective spans and the parts A_3, A_4 and A_5, A_6 due to end moments M_A, M_B on span AB and M_B, M_C on span BC . The simple-beam moment diagrams due to loads applied on the spans are known in advance, and the objective of the analysis is to find the bending moments M_A, M_B , and M_C at the supports.

A relation between M_A, M_B , and M_C may be derived from the compatibility condition that the beam is continuous at B , or the tangent at B to the elastic curve BA' is on the same straight line as the tangent at B to the elastic curve BC' , as shown in Fig. 4.1a. In other words the joint B can be considered a rigid joint (monolithic in reinforced concrete construction, welded in steel construction); thus the two tangents at B to the elastic curves on both sides of B must remain at 180° to each other. Since the tangent A_1BC_1 in Fig. 4.1a must be a straight line,

$$\frac{AA_1}{L_1} = \frac{CC_1}{L_2} \quad (4.1)$$

In which

$$\begin{aligned} AA_1 &= h_A - A_1A' = h_A - (\text{Deflection of } A' \text{ from the tangent at } B) \\ &= h_A - \frac{1}{EI_1} \left(A_1a_1 + \frac{1}{3}A_3L_1 + \frac{2}{3}A_4L_1 \right) \\ &= h_A - \frac{1}{EI_1} \left(A_1a_1 + \frac{1}{6}M_AL_1^2 + \frac{1}{3}M_BL_1^2 \right) \end{aligned} \quad (4.2)$$

And

$$\begin{aligned} CC_1 &= C_1C' - h_C = (\text{Deflection of } C' \text{ from the tangent at } B) - h_C \\ &= \frac{1}{EI_2} \left(A_2a_2 + \frac{2}{3}A_5L_2 + \frac{1}{3}A_6L_2 \right) - h_C \\ &= \frac{1}{EI_2} \left(A_2a_2 + \frac{1}{3}M_BL_2^2 + \frac{1}{6}M_CL_2^2 \right) - h_C \end{aligned} \quad (4.3)$$

Substituting Eqs. (4.2) and (4.3) into Eq. (4.1),

$$\frac{h_A}{L_1} - \frac{1}{L_1EI_1} \left(A_1a_1 + \frac{1}{6}M_AL_1^2 + \frac{1}{3}M_BL_1^2 \right) = \frac{1}{L_2EI_2} \left(A_2a_2 + \frac{1}{3}M_BL_2^2 + \frac{1}{6}M_CL_2^2 \right) - \frac{h_C}{L_2}$$

Multiplying every term in the above equation by $6E$ and reducing,

$$M_A \left(\frac{L_1}{I_1} \right) + 2M_B \left(\frac{L_1}{I_1} + \frac{L_2}{I_2} \right) + M_C \left(\frac{L_2}{I_2} \right) = -\frac{6A_1a_1}{L_1I_1} - \frac{6A_2a_2}{L_2I_2} - \frac{6Eh_A}{L_1} - \frac{6Eh_C}{L_2} \quad (4.4)$$

Equation (4.4) is the three-moment equation.

When there is no settlement of supports, $h_A = 0$ and $h_C = 0$ and Eq. (4.4) reduces to

$$M_A \left(\frac{L_1}{I_1} \right) + 2M_B \left(\frac{L_1}{I_1} + \frac{L_2}{I_2} \right) + M_C \left(\frac{L_2}{I_2} \right) = -\frac{6A_1a_1}{L_1I_1} - \frac{6A_2a_2}{L_2I_2} \quad (4.5)$$

Example No.1 Analyze the two span continuous beam shown in Fig. 4.3(a) by using the three-moment equation. Draw the shear force and bending moment diagrams.

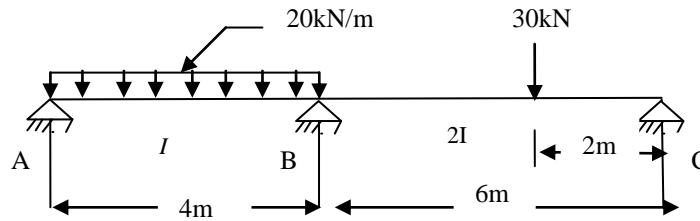

(a) Given Beam

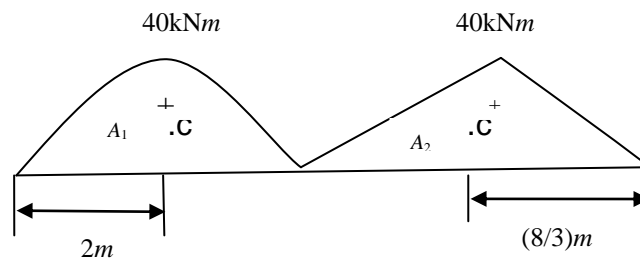

(b) Bending moment diagrams on simple spans due to loads

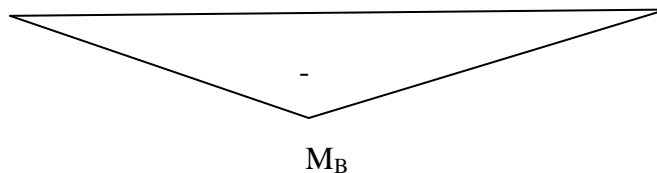

(c) Bending moment diagrams on simple spans due to end moment

Fig. 4.3 Continuous beam of Example No. 1

Solution: The bending moment diagrams on AB and BC obtained by considering each span as a simple beam subjected to the applied loads are shown in Fig. 4.3b. The bending moment diagram (BMD) for span AB is a parabola with maximum ordinate

$$= \frac{20 \times 4^2}{8} = 40 \text{ kNm at mid span.}$$

The BMD for span BC is a triangle with maximum ordinate

$$= \frac{30 \times 4 \times 2}{6} = 40 \text{ kNm at distance } 2\text{m from the support C.}$$

Area of the BMD in span AB , $A_1 = \frac{2}{3} \times 4 \times 40 = 106.67$

Distance of the cg of BMD in span AB from end A , $a_1 = 2\text{m}$

Area of the BMD in span BC , $A_2 = \frac{1}{2} \times 40 \times 6 = 120$

Distance of the cg of BMD in span BC from end C , $a_2 = \frac{6+2}{3} = \frac{8}{3}m$

Fig. 4.3c shows separate moment diagrams on simple spans due to end moments. By principle of superposition bending moment (BM) at any section can be determined from the above BM diagrams as shown in Fig 4.3 a, b.

Applying the three-moment equation to Spans AB and BC :

$$M_A \left(\frac{L_1}{I_1} \right) + 2M_B \left(\frac{L_1}{I_1} + \frac{L_2}{I_2} \right) + M_C \left(\frac{L_2}{I_2} \right) = -\frac{6A_1 a_1}{L_1 I_1} - \frac{6A_2 a_2}{L_2 I_2}$$

Since, $L_1=4m$, $L_2=6m$, $L_1=I_1$, and $L_2=2I_2$. By inspection, $M_A = 0$ and $M_C = 0$, we get

$$2M_B \left(\frac{4}{I} + \frac{6}{2I} \right) = -\frac{6 \times 106.67 \times 2}{I \times 4} - \frac{6 \times 120 \times (8/3)}{2I \times 6}$$

$$M_B = -34.28 kNm$$

Determination of Reactions:

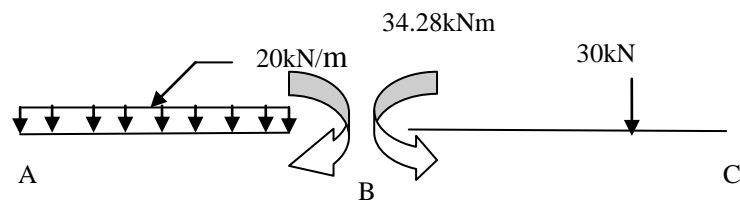

<i>End reactions due to applied loads</i>	+40 ↑	+40 ↑	+10 ↑	+20 ↑
<i>End reactions due to end moments</i>	-8.57 ↓	+8.57 ↑	+5.71 ↑	-5.71 ↓
<i>Total end reactions</i>	+31.43 ↑	+48.57 ↑	+15.71 ↑	+14.29 ↑
	$R_A = 31.43$ ↑	$R_B = 48.57$ ↑		$R_C = 14.29$ ↑

(a) Calculation of Reaction

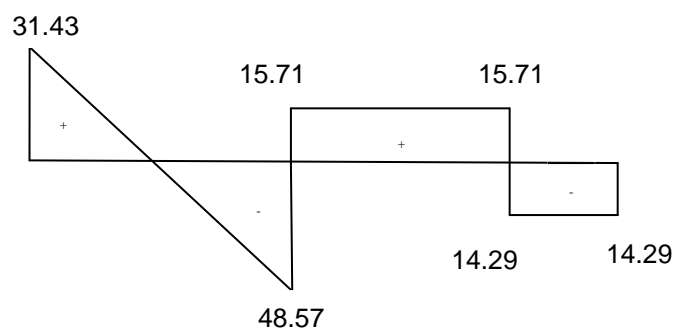

(b) SFD

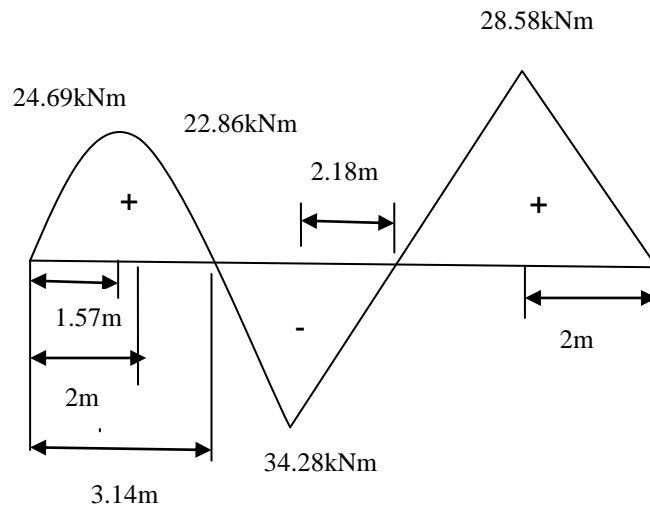

(c) **BMD**

Fig. 4.4 Solution of Example No. 1

The reactions are determined as shown in Fig. 4.4a. The total reaction at the end of each span is equal to the sum of the reaction due to loads applied on the span and that due to the moments at the ends of the span. For instance, the sum of the end moment acting on span *BC* is 34.28 kNm counter-clockwise, which requires a clockwise reaction couple, or an upward reaction of $34.28/6 = 5.71\text{ kN}$ at *B* and a downward reaction of 5.71 kN at *C*. The total reaction to the continuous beam at support *B* is equal to the sum of the end reactions at *B* to spans *BA* and *BC*, or $R_B = 48.57 + 15.71 = 64.28\text{ kN}$. After all the reactions are determined, the shear diagram is drawn using the basic principle as shown in Fig. 4.4b. Similarly the bending moment diagram is plotted as shown in Fig. 4.4c. The point of contra-flexure and maximum bending moment are mentioned thereon.

Example No.2 Analyze the continuous beam shown in Fig. 4.5a by using the three-moment equation. Draw shear and moment diagrams.

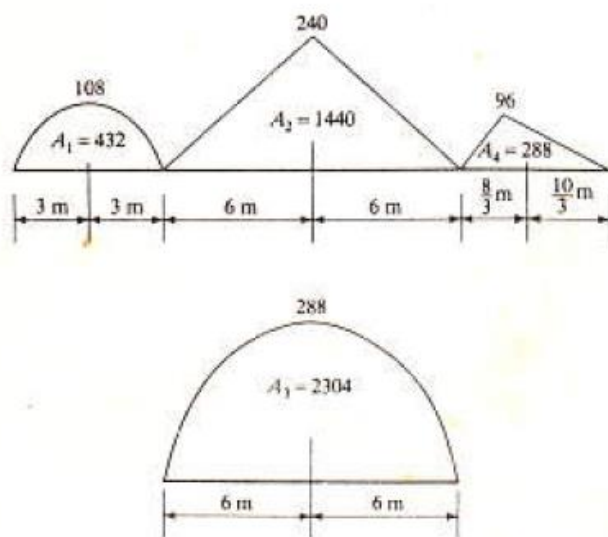
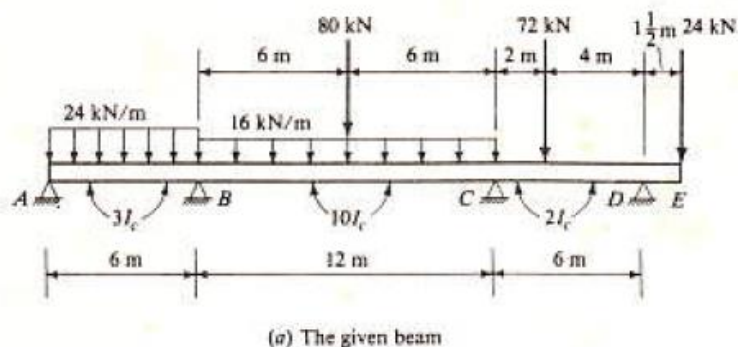

(b) bending moment diagrams on simple spans due to applied loads
Fig. 4.5 Continuous beam of Example No. 1

Solution: - The moment diagrams on AB, BC, and CD, obtained by considering each span as a simple beam subjected to the applied loads, are shown in Fig. 4.5b. Note that, for span BC, separate moment diagrams are drawn for the uniform load and for the concentrated load. By inspection, $M_A = 0$ and $M_D = -36kN.m$ (negative because it causes compression in the lower part of the beam at D).

Applying the three-moment equation (i.e. Eq.(4.4)) to

(i) Spans AB and BC:

$$M_A \left(\frac{6}{3I_c} \right) + 2M_B \left(\frac{6}{3I_c} + \frac{12}{10I_c} \right) + M_C \left(\frac{12}{10I_c} \right) = -\frac{6(432)(3)}{6(3I_c)} - \frac{6(1440)(6)}{12(10I_c)} - \frac{6(2304)(6)}{12(10I_c)}$$

(ii) Spans BC and CD:

$$M_B \left(\frac{12}{10I_C} \right) + 2M_C \left(\frac{12}{10I_C} + \frac{6}{2I_C} \right) + M_D \left(\frac{6}{2I_C} \right) = -\frac{6(1440)(6)}{12(10I_C)} - \frac{6(2304)(6)}{12(10I_C)} - \frac{6(288)(10/3)}{6(2I_C)}$$

Simplifying,

$$6.4M_B + 1.2M_C = -1555.2$$

$$1.2M_B + 8.4M_C = -1495.2$$

Solving above two Equations,

$$M_B = -215.39 \text{ kN.m}$$

$$M_C = -147.23 \text{ kN.m}$$

The reactions are determined as shown in Fig 4.6a. The total reaction at the end of each span is equal to the sum of the reaction due to loads applied on the span and that due to the moments at the ends of the span. For instance, the sum of the end moment acting on span BC is $215.39 - 147.23 = 68.16 \text{ kN.m}$ counterclockwise, which requires a clockwise reaction couple, or an upward reaction of $68.16/12 = 5.680 \text{ kN}$ at B and a downward reaction of 5.680 kN at C. The total reaction to the continuous beam at support B is equal to the sum of the end reactions at B to spans BA and BC, or $R_B = 107.898 + 141.680 = 249.578 \text{ kN}$. After all the reactions are determined, the shear diagram is drawn using the basic principle as shown in Fig. 4.6b. The point of zero shear on span AB is at $36.102/24 = 1.504 \text{ m}$ from support A. Similarly the bending moment diagram is plotted as shown in Fig. 4.6c.

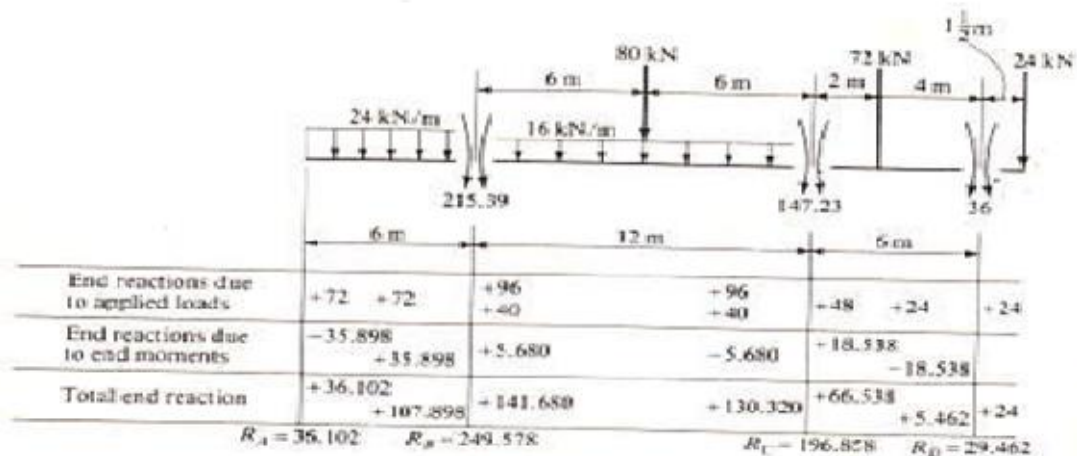

(a) Determination of reactions

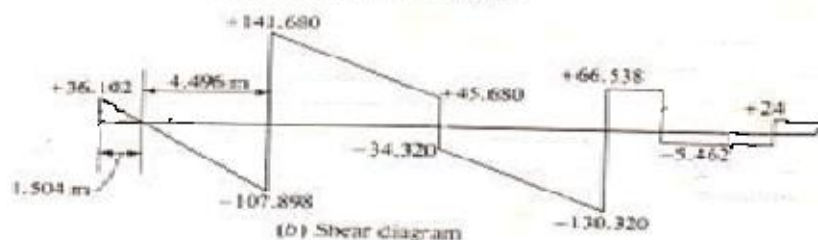

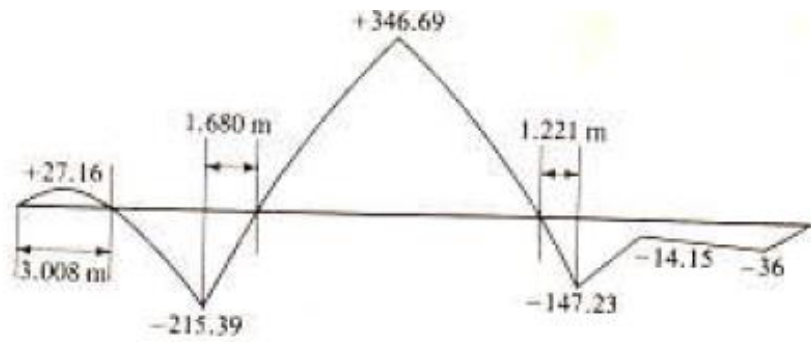

(c) Bending moment Diagram

Fig. 4.6 Shows Calculation of Reactions, Shear Force diagram and Bending moment

4.2. Application of Three-Moment Equation to analysis of Continuous beam having a fixed end

If the continuous beam has a fixed end, as shown in Fig. 4.7, the bending moment at the fixed support is one of the unknown redundant. The compatibility condition corresponding to the unknown fixed end moment is that the slope of the tangent at A is zero. This condition can be met by adding an imaginary span A_0A of any length L_0 simply supported at A_0 and having an infinitely large moment of inertia for its cross section. In this way a three-moment equation using the fixed support A as the middle support can be written. Since the imaginary span A_0A has infinitely large moment of inertia, the moment diagram on it, whatever it may be, can yield no M/EI area, hence no elastic curve. So long as A_0A remains un-deformable, the common tangent at A is a horizontal straight line.

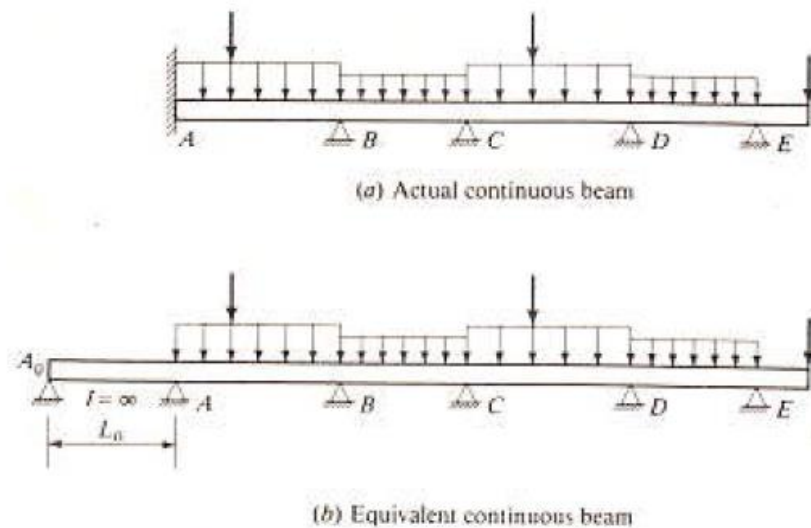

Fig. 4.7 A typical continuous beam with one end fixed

EXERCISES

1. A continuous beam, ABC, of two spans AB and BC of 4m each, is subjected to a uniformly distributed load of 10 kN/m for the full spans. A and C are the end simple supports and B is the continuous support. Draw the BMD and SFD for the above beam.

2. A continuous beam, ABC, of two spans AB and BC of 5m each, is subjected to a concentrated load of 10 kN at the mid of each span. A and C are the end simple supports whereas B is the continuous support. Draw the BMD and SFD for the above beam.

3. A continuous beam, ABC, of two spans AB and BC of 3.6m each, is subjected to a concentrated load of 10 kN at the mid of each span. Consider the end A is as fixed end support, C is the end simple support whereas B is the continuous support. Draw the BMD and SFD for the above beam.

4. Analyze the continuous beam as shown in the figure below by using the three-moment equation. Draw shear force and bending moment diagrams

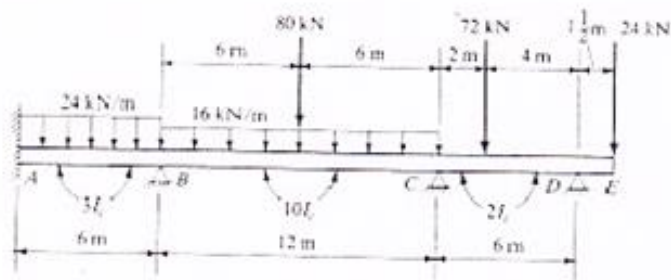

CHAPTER – 5

MOMENT DISTRIBUTION METHOD FOR INDETERMINATE STRUCTURES

Introduction

The moment distribution method also known as Hardy cross method which is one of the convenient method of handling the stress analysis of rigid jointed structure. It is essentially consists in solving the simultaneous equations of the slope deflection method by successive approximation using Gauss Sudil iteration.

The fundamental principle of moment distribution can be well explained referring to the structure shown in fig. 5.1. The supports at ABCD are fixed and are unyielding and have no joint rotation. The members OA,OB,OC& OD are joined together at O,so that angle between the members do not change when joints rotate under load.

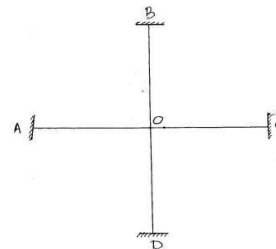

In this method the joint O is initially assumed to be locked and the fixed end moment are calculated due to external load on each of these members. Thus total moment at O is the sum of all fixed end moments due to members OA,OB,OC& OD. Since the external moment applied at O is Zero, The next step is to release the joint moment at O by applying a moment opposite to that of moment developed at O due to fixed end moment at O. Thus the moment at far end A,B,C,& D will be developed depending upon stiffness of corresponding member. Thus fraction of the total balancing moment which is distributed to a particular member can be found by dividing the stiffness of that member by sum of stiffness of all members.

The factor by which the balancing moment is multiplied in order to obtain the distributed moment is called distribution factor for the member.

The addition of a distributed moment to one end of the member usually involves a moment at the other end, if the latter is restrained against rotation. That moment is called carry over moment and the factor by which the moment is induced to the near end moment is called carry over factor.

Sign Conversion for moments

At a joint of moment is acting clockwise is considered +ve and of acting anticlockwise considered –ve.

Fixed End Moment.

The first step in the moment distribution procedure is to lock the joints against rotation and determine the fixed end moment resulting from loads.

Rotational Stiffness

The balancing moment is distributed to the members meeting at a joint of the structure in proportion to their rotational stiffness, the rotational stiffness being a measure of the resistance of the beam to the rotation at one end.

If far end is fixed the relative stiffness is

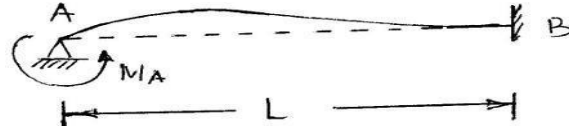

The relative stiffness is taken equal to

$$K = 3/4 \frac{EI}{L}$$

Where K = relative stiffness of member.

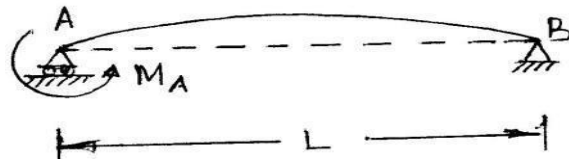

Distribution Factor.

The ‘distribution factor’ is the fraction of total balancing moment which is distributed to a particular member, since the members meeting at a joint rotates through the same angle, it follows that the distribution factor is the ratio of stiffness K of that member to the sum of stiffness of all members meeting at that joint.

$$\text{Distribution factor } D.F = \frac{K}{\sum K}$$

Thus the distribution factor for member OA of Fig 5.1 can be expressed as

$$D.F_{OA} = \frac{K_{OA}}{K_{OA} + K_{OB} + K_{OC} + K_{OD}}$$

$$D.F_{OA} = \frac{K_{OA}}{\sum K}$$

5.1. Analysis of Propped Cantilever.

Consider a propped Cantilever AB Fixed at A and simply supported at B, having span ‘L’ and Loaded with udl ‘w’ per unit length

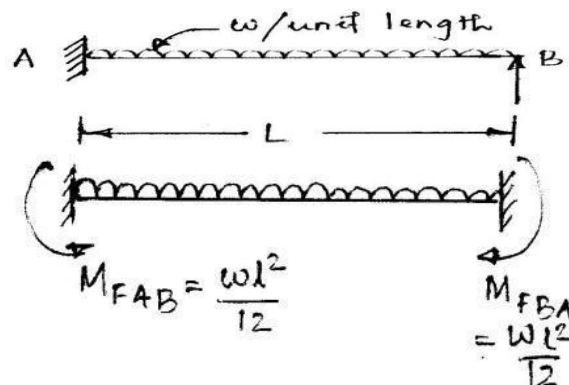

Step – 1

Assuming both ends fixed

Fixed end moments

$$M_{FAB} = -\frac{WL^2}{12}$$

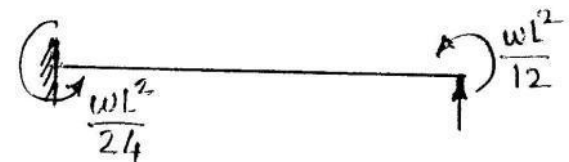

$$M_{FBA} = + \frac{WL^2}{12}$$

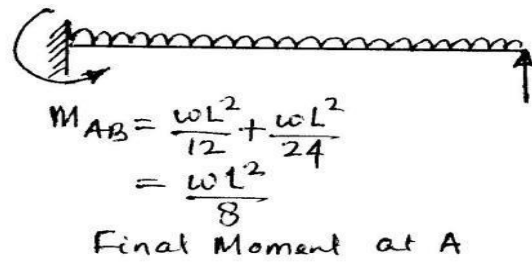

Step – 2

As the end B is simply supported moment at B should be zero. External moment $-\frac{WL^2}{12}$ has been applied at B which is called unbalanced moment after releasing the fixed end at B.

Step – 3

Due to the applied load at B of magnitude $\frac{WL^2}{12}$ an moment of $-\frac{WL^2}{24}$ will be developed at A which is called carry over moment

Step – 4

The final moment at A will be

$$\begin{aligned}
 &= -\frac{WL^2}{12} - \frac{WL^2}{24} \\
 &= -\frac{WL^2}{8}
 \end{aligned}$$

Joint	A	B
Members	AB	BA
Distribution Factor	--	1
FEM	$-\frac{WL^2}{12}$	$+\frac{WL^2}{12}$
Balancing	--	$-\frac{WL^2}{12}$
C.O	$-\frac{WL^2}{24}$	--
Final Moment	$-\frac{WL^2}{8}$	0

Example: 5.2

Joints	A	B
	C	

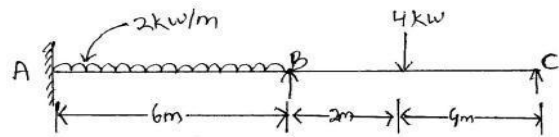

Fig: 5-2

Analyse the continuous beam as shown in Fig 5.2 by method of moment distribution the EI of all member is same.

Solution.

Fixed end moments

$$M_{FAB} = -\frac{2 \times 6^2}{12} = -6 \text{ KN-m}$$

$$M_{FBA} = +6 \text{ KN-m}$$

$$M_{FBC} = -\frac{4 \times 2 \times 3^2}{6^2} = -2 \text{ KN-m}$$

$$M_{FCB} = +\frac{4 \times 3 \times 2^2}{6^2} = +1.333 \text{ KN-m}$$

Relative stiffness of members at joint B

$$K_{BA} = I/6$$

$$K_{BC} = 3/4 = I/6$$

Distribution Factor

$$DF_{BA} = \frac{K_{BA}}{\Sigma K} = \frac{I/6}{\frac{I}{6} + \frac{3}{4}I/6} = \frac{1}{(1+3/4)}$$

$$DF_{BC} = \frac{K_{BC}}{\Sigma K} = \frac{3/4 I/6}{\frac{I}{6} + 3/4 I/6} = \frac{4}{7}$$

$$= 3/7$$

Members	AB BA	BC CB	
D.F	1 4/7	3/7	0
FEM	-6	-2	
Balancing	+6	+1.333	-
		1.333	
C.O		-0.667	
Total Members	-6 +6	-2.667 0	
Balancing Joint	-	-1.429	
B_{CO}	-0.952		
Final Moment	-6.952 +4.096	-4.096 0	

$$M_A = -6.952 \text{KN-m}$$

$$M_B = 4.096 \text{KM-m}$$

$$M_C = 0$$

Shear Force and Bending Moment Diagram

Let us find out the support reactions considering the portion BC

Taking moment about B

$$R_{CB} \times 6 = 4 \times 2 - 4.096$$

$$R_{CB} = \frac{8 - 4.096}{6}$$

$$= 0.65 \text{KN}$$

$$R_{BC} = 4 - 0.65$$

$$= 3.35 \text{KN}$$

Considering portion AB

Taking Moment about A

$$R_{BA} \times 6 = 2 \times 6 \times 3 + 4.096 - 6.952$$

$$= 33.144$$

$$R_{BA} = \frac{33.144}{6} = 5.524 \text{KN}$$

$$R_A = 12 - 5.524 = 6.476 \text{KN.}$$

$$R_B = 5.524 + 3.35 = 8.874 \text{KN.}$$

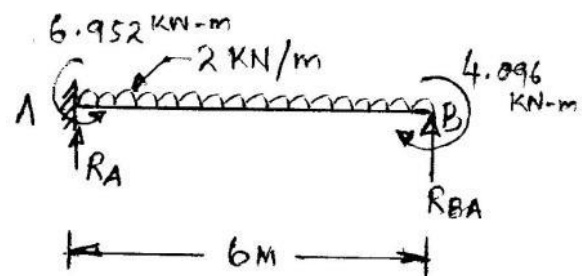
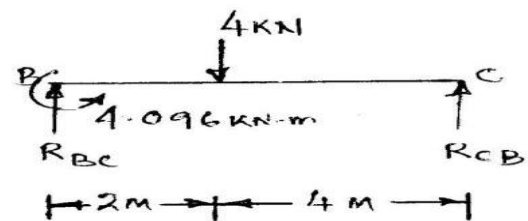

$$R_C = 0.65 \text{ KN}$$

$$\text{SF at C} = -0.65 \text{ KN}$$

$$\begin{aligned} \text{SF to the left of 4KN load} \\ &= -0.65 + 4 \\ &= 3.35 \text{ KN} \end{aligned}$$

$$\begin{aligned} \text{SF just left of B} \\ &= 3.35 - 8.874 \\ &= -5.524 \text{ KN} \end{aligned}$$

$$\begin{aligned} \text{SF just to right of A} \\ &= -5.524 + 12 \\ &= 6.476 \text{ KN} \end{aligned}$$

$$\begin{aligned} \text{Bending Moment under load in span BC} \\ &= \frac{4 \times 2 \times 4}{6} \\ &= 5.33 \text{ KN-m} \end{aligned}$$

$$\begin{aligned} \text{Bending Moment due to udl t mid span of AB} \\ &= \frac{2 \times 6^2}{8} \\ &= 9 \text{ KN-m} \end{aligned}$$

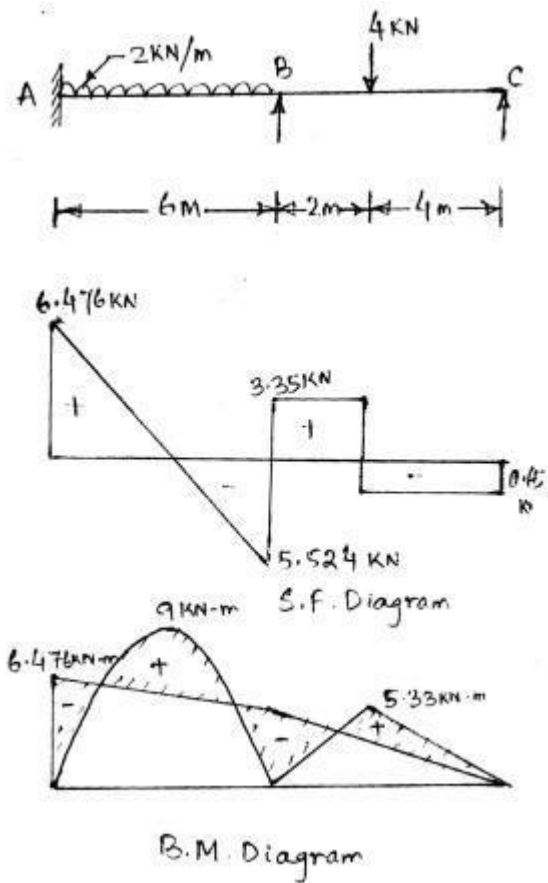

5.3

Analyse the continuous beam with an overhang as shown in fig 5.3 by moment distribution method. Assume $E I$ Constant for all spans.

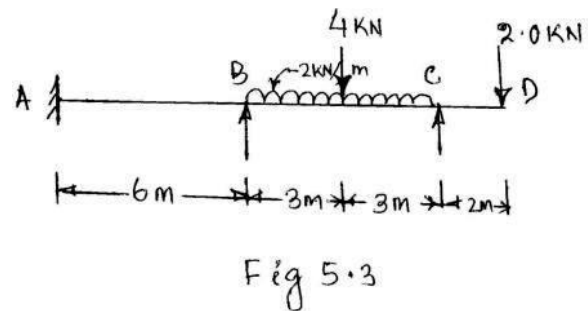

Solution :

Fixed End moment

$$M_{FAB} = 0$$

$$M_{FBA} = 0$$

$$\begin{aligned} M_{FBC} &= -\frac{2 \times 6^2}{12} - \frac{4 \times 6}{8} \\ &= -9 \text{ KN} - m. \end{aligned}$$

$$M_{FCB} = +9\text{KN-m}$$

$$M_{FCD} = -9\text{KN-m}$$

Distribution factor at Joint B

$$DF_{BA} = \frac{K_{BA}}{\Sigma K} = \frac{I/6}{\frac{I}{6} + \frac{3I}{4}}$$

$$= 4/7$$

$$DF_{BC} = 3/7$$

Joints	A	B		C	
Members	AB	BA	BC	C B	C D
D.F	—	4/7	3/7	1	0
FEM	—	—	-9	+9	-4
Balancing 'C'				-5	
Carry Over			-2.5		
Total Moment	—	—	-11.5	4	-4
Balancing at B		+6.57	+4.93		
Carry Over	3.285				
Final Moment	3.285	6.57	-6.57	4	-4

Final Support moments

$$M_A = 3.285\text{KN-m}$$

$$M_B = -6.57\text{KN-m}$$

$$M_C = -4\text{KN-m}$$

Shear force and Bending Moment

Let us consider the portion CD

$$\Sigma V = 0$$

$$R_{CD} = 2\text{KN}$$

Considering portion BC

Taking moment about 'B'

$$R_{CB} \times 6 = 4 \times 3 + 2 \times 6 \times 3 + 6.57 - 4$$

$$= 50.57$$

$$R_{CB} = \frac{50.57}{6} = 8.43 \text{ KN}$$

$$R_{BC} = 16 - 8.43 = 7.57 \text{ KW}$$

$$R_C = 8.43 + 2 = 10.43 \text{ KW}$$

Considering Portion AB

Taking moment About 'A'

$$R_{BA} \times 6 = 6.57 + 3.285$$

$$R_{BA} = \frac{6.57 + 3.285}{6}$$

$$= 1.64 \text{ KN}$$

$$R_A = -1.64 \text{ KN}$$

$$R_B = 1. + 7.57 = 9.21 \text{ KW}$$

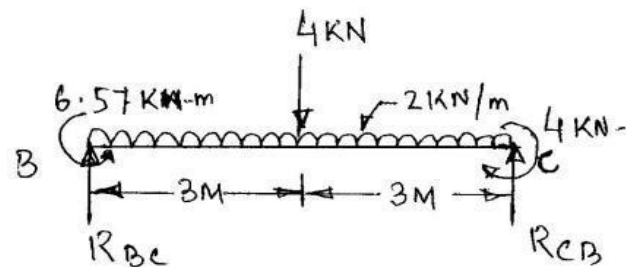
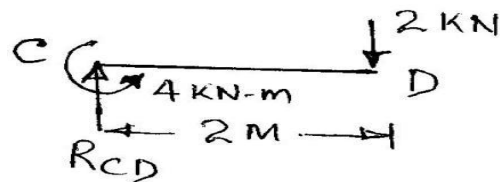

Shear Force & Bending Moment Diagram

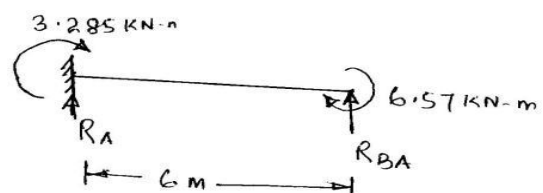

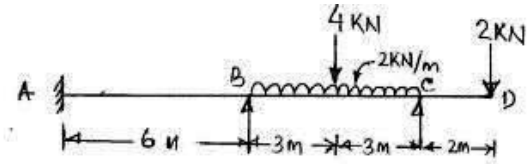
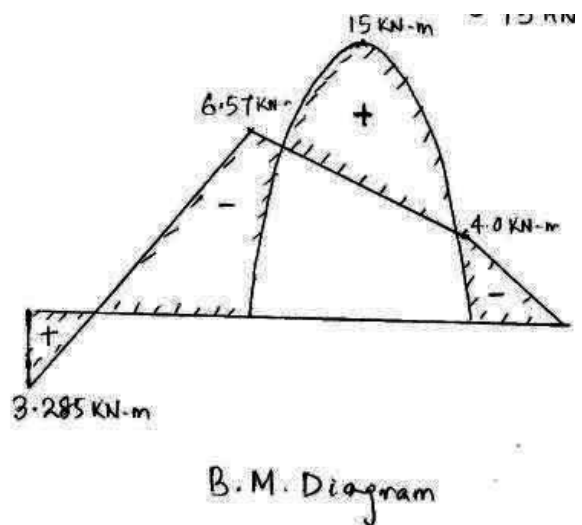
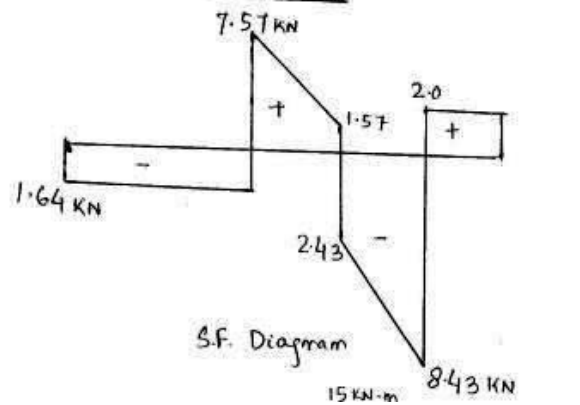

FIG. 5.3



Bending Moment

$M_C = -2 \times 2 = 4 \text{ kN.m}$
 BM between to B will be 3.285 kN.m
 parabolic with maximum at mid span due to loading

$$\begin{aligned}
 &= -\frac{2 \times 6^2}{8} + \frac{4 \times 6}{4} \\
 &= 9 + 6 = 15 \text{ kN-m}
 \end{aligned}$$

Analysis of Symmetrical portal frame without sway

The Portal frame consists of number of members rigidly connected at joints so that angle between members remains same after loading.

In case of symmetrical frames with symmetrical loading the joints will only rotate and there is no joint displacement. Such frames are said to have no sway. The analyses of such frames are done in usual way as for continuous beams. The fixed end moments are calculated assuming various members fixed at ends. The unbalanced moment are distributed as a joint

depending on the distribution factor of adjacent members meeting at that joint. The process of moment distribution is continued till the carryovers are negligibility small.

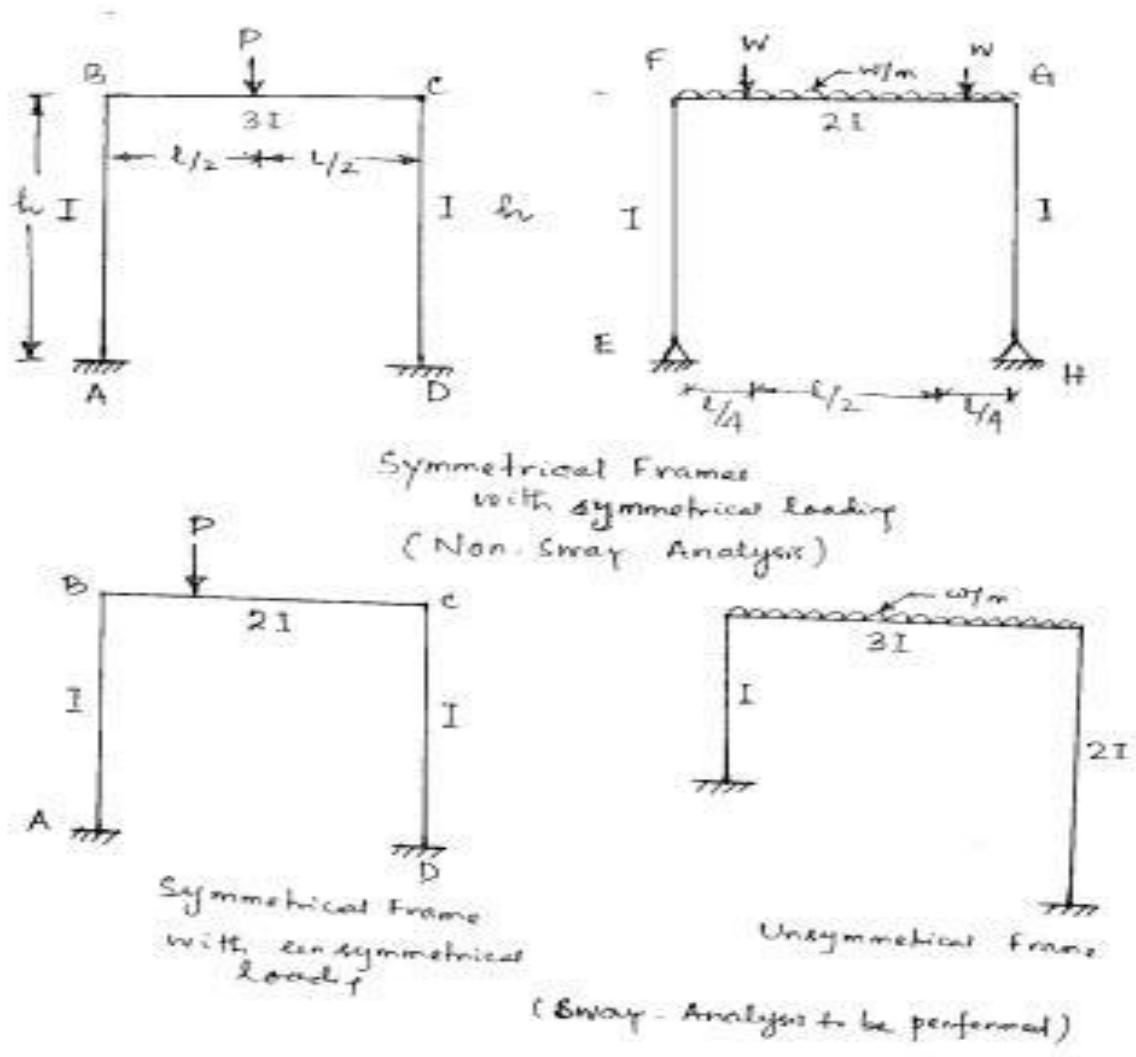

Example 5.4

Analyse the portal frame as shown in Fig. 5.4 by moment Distribution Method.

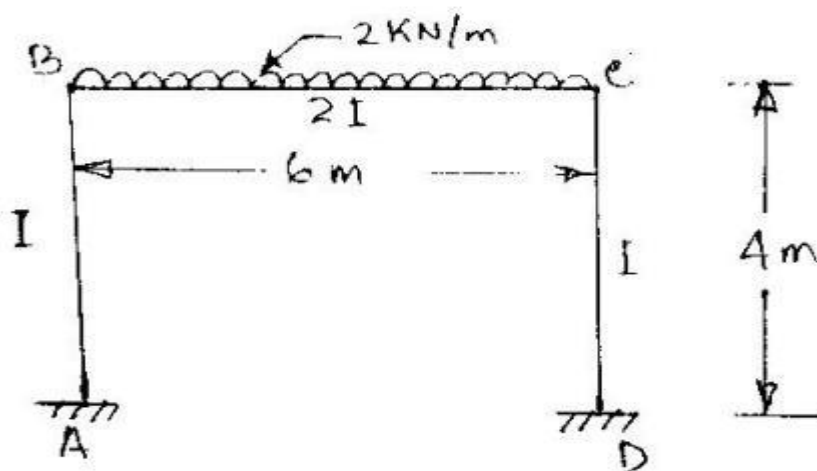

Fig-5.4

The frame is symmetrical with symmetrical loading, hence subjected to no sway.

Fixed end moments

$$M_{FAB} = 0$$

$$M_{FBA} = 0$$

$$M_{FBC} = -\frac{2 \times 6^2}{12} = -6 \text{ KN.m}$$

$$M_{FCB} = -\frac{2 \times 6^2}{12} = 6 \text{ KN.m}$$

$$M_{FCD} = 0$$

$$M_{FDC} = 0$$

Distribution factor at B

$$\begin{aligned} DF_{BA} &= \frac{K_{BA}}{K_{BA} + K_{BC}} \\ &= \frac{I/4}{I/4 + 2I/6} = \frac{1/4}{7I/12} \\ &= I/4 \times \frac{12}{7I} \\ &= 3/7 \end{aligned}$$

$$\begin{aligned} DF_{BC} &= \frac{2I/6}{I/4 + 2I/6} = \frac{2I/6}{7I/12} \\ &= \frac{2I}{6} \times \frac{12}{7I} \\ &= \frac{4}{7} \end{aligned}$$

Similarly distribution factor at C

$$DF_{CB} = \frac{4}{7}$$

$$DF_{CD} = \frac{3}{7}$$

Joints	A	B		C		D
Members	AB	BA	BC	CB	CD	DC
D.F	--	3/7	4/7	4/7	3/7	---
FEM			-6	+6		
Balancing Joint B & C		2.571	3.429	-3.429	-2.571	
C.O	0.367		-0.490	0.490		-0.367
Balancing Joint B & C		0.734	0.980	-0.980	-0.734	
C.O	0.367		-0.490	0.490		-0.367
Balancing Joint B & C		0.210	0.280	-0.280	-0.210	
C.O	0.105		-0.140	0.140		-0.105
Balancing Joint B & C		0.06	0.08	-0.08	-0.06	

C.O	0.03					-0.03
Final Moment	1.788	3.575	-3.575	3.575	-3.575	-1.788

$$\begin{aligned}
 M_{AB} &= 1.788 \text{ KN-m} \\
 M_{BA} &= 3.575 \text{ KN-m} \\
 M_{BC} &= -3.575 \text{ KN-m} \\
 M_{CB} &= 3.575 \text{ KW-m} \\
 M_{CD} &= -3.575 \text{ KN-m} \\
 M_{DC} &= -1.788 \text{ KN-m}
 \end{aligned}$$

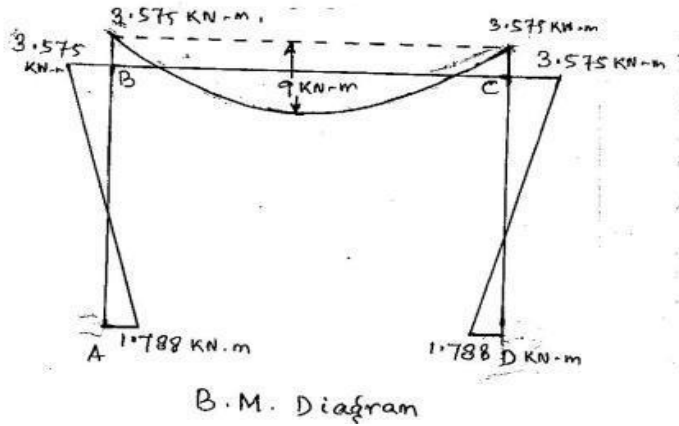

Example 5.5

Analyse the frame shown in fig 5.5 by moment distribution Method

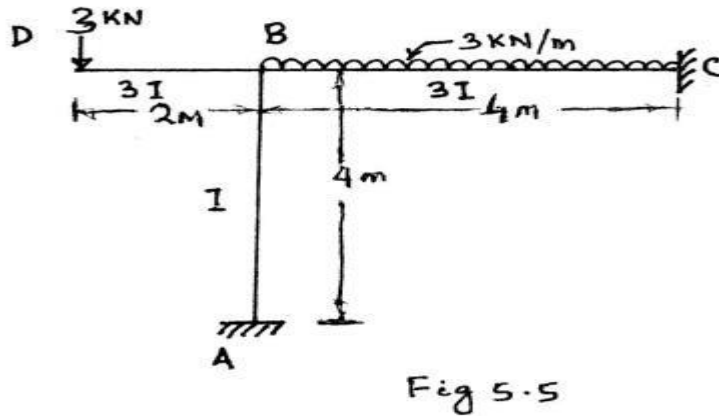

Fixed end moment

$$M_{FBD} = +6 \text{ KN-m}$$

$$M_{FBC} = -\frac{3 \times 4^2}{12} = -4 \square \square \square$$

$$M_{FCB} = \frac{3 \times 4^2}{12} = 4 \square \square \square$$

As the end D is free stiffness of member BD = 0

$$DF_{BC} = \frac{3I/4}{\frac{3I}{4} + I/4} = \frac{3}{7}$$

$$M_{BA} = 1/4$$

Joints	A	B			C
Members	AB	BA	BD	BC	CB
D.F	---	1/4	--	3/4	--
FEM	--	--	+6	-4	+4
Balancing Joint		-0.5		-1.5	
C.O	-0.25				-0.75
Final Moment	-0.25	-0.50	+6.0	-5.5	3.25

$$M_{AB} = -0.25 \text{ KN-m}$$

$$M_{BA} = -0.5 \text{ KN-m}$$

$$M_{BD} = 6.0 \text{ KN-m}$$

$$M_{BC} = -5.5 \text{ KN-m}$$

$$M_{CB} = 3.25 \text{ KN-m}$$

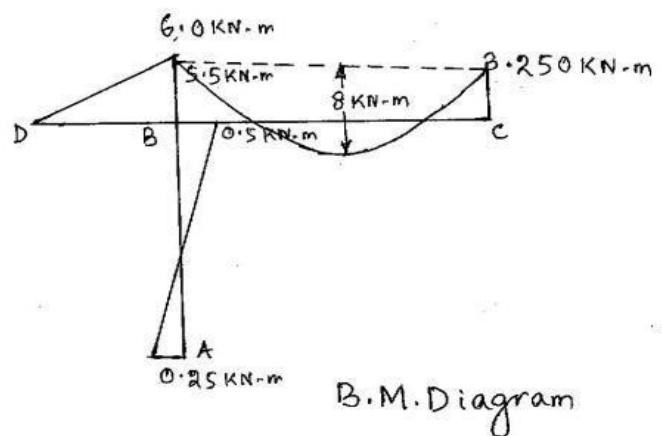

CHAPTER-6

COLUMNS AND STRUTS

Introduction:-

A structural member, subjected to an axial compressive force, is called a strut. As per definition, a strut may be horizontal, inclined or even vertical. But a vertical strut, used in buildings or frames, is called a column.

Definition of Column

A long slender bar subjected to axial compression is called a column.

The term is frequently used to describe a vertical member. Sometimes direct stresses dominate and sometimes flexural or bending stresses dominate.

Axial Compression means the compressive forces act at the two ends of the member in the opposite direction and are along the same axis.

Difference between column and strut

The difference between column and strut is that former is used to describe a vertical member whereas latter is used for the inclined members.

Short Column

The failure initiates due to crushing of material and direct stresses are dominant. For short column, if

$$L < 4d \text{ and } kL/r_{\min} < 30$$

Where

d = least lateral dimension.

L = Unbraced length of the column.

k = effective length factor depends upon the end conditions of the column.

r_{\min} = least radius of gyration.

Slender or long Column

In these, failure initiates due to lateral buckling and flexural stresses are dominant. If

$$L > 30d$$

or

$kL/r_{\min} >$ critical slenderness ratio.

Slenderness Ratio

The tendency of the column to buckle (fail) with ease under the action of axial compressive load is measured by a parameter known as slenderness ratio which is usually defined as the ratio of equivalent (or unsupported) length of column to the least radius of gyration of the column section. It is obviously unit less.

Failure of a Column or Strut:-

It has been observed, that when a column or a strut is subjected to some compressive force, then the compressive stress induced,

$$\sigma = \frac{P}{A}$$

Where $P =$ Compressive force and

$A =$ Cross-sectional area of the column.

A little consideration will show that if the force or load is gradually increased the column will reach a stage, when it will be subjected to the ultimate crushing stress. Beyond this stage, the column will fail by crushing. The load corresponding to the crushing stress, is called crushing load.

It has also been experienced that sometimes, a compression member does not fail entirely by crushing, but also by bending *i.e.*, buckling. This happens in the case of long columns. It has also been observed that all the short columns fail due to their crushing. But, if a long column is subjected to a compressive load, it is subjected to a compressive stress. If the load is gradually increased, the column will reach a stage, when it will start buckling. The load, at which the column is said to have developed an elastic instability, is called buckling load or crippling load. A little consideration will show that for a long column, the value of buckling load will be less than the crushing load. Moreover, the value of buckling load is low for long columns and relatively high for short columns.

Euler's Column Theory:-

The first rational attempt, to study the stability of long columns, was made by Mr. Euler. He derived an equation, for the buckling load of long columns based on the bending stress. While deriving this equation, the effect of direct stress is neglected. This may be justified with the statement that the direct stress induced in a long column is negligible as compared to the bending stress. It may be noted that the

Euler's formula cannot be used in the case of short columns, because the direct stress is considerable and hence cannot be neglected.

Assumptions in the Euler's Column Theory:-

The following simplifying assumptions are made in the Euler's column theory:-

1. Initially the column is perfectly straight and the load applied is truly axial.
2. The cross-section of the column is uniform throughout its length.
3. The column material is perfectly elastic, homogeneous and isotropic and thus obeys Hooke's law.
4. The length of column is very large as compared to its cross-sectional dimensions.
5. The shortening of column, due to direct compression (being very small) is neglected.
6. The failure of column occurs due to buckling alone.

Sign Conventions:-

Though there are different signs used for the bending of columns in different books, yet we shall follow the following sign conventions which are commonly used and internationally recognized.

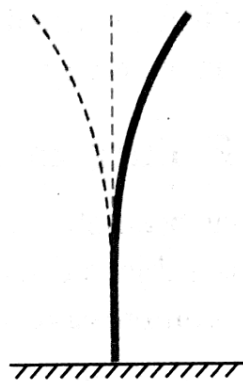

(a) Positive

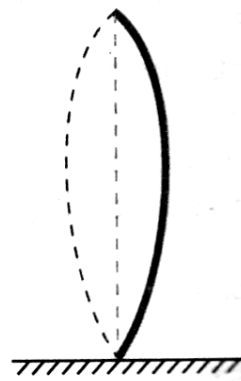

(b) Negative

1. A moment, which tends to bend the column with convexity towards its initial central line as shown in (a) is taken as positive.
2. A moment, which tends to bend the column with convexity towards its initial central line as shown in (b) is taken as negative.

Types of end Conditions of Columns:-

In actual practice there are a number of end conditions for columns. But usually four types are important from subject point of view. They are as follows:

- Both ends hinged

- Both ends fixed
- One end is fixed and other end is hinged, and
- One end is fixed and other end is free.

Columns with both ends hinged (Derivation of expression for Critical load)

Consider a column AB of length l hinged at both of its ends A and B and carrying a critical load at B . As a result of loading, let the column deflect into a curved form AX_1B as shown in Figure below.

Now consider any section X , at a distance x from A .

Let $P =$ Critical load on the column,
 $Y =$ Deflection of the column at X .

\therefore Moment due to the critical load P ,

$$M = -P \cdot y$$

$\therefore EI \frac{d^2 y}{dx^2} = -P \cdot y \quad \dots$ (Minus sign due to
 Concavity towards initial
 Centre line)

$\therefore EI \frac{d^2 y}{dx^2} + P \cdot y = 0$

or $\frac{d^2 y}{dx^2} + \frac{P}{EI} \cdot y = 0$

The general solution of the above differential equation is

$$y = A \cdot \cos\left(x \sqrt{\frac{P}{EI}}\right) + B \sin\left(x \sqrt{\frac{P}{EI}}\right)$$

Where A and B are the constants of integration. We know that when $x=0, y=0$.

Therefore $A=0$, Similarly when $x=l$, then $y=0$. Therefore

$$0 = B \sin\left(l \sqrt{\frac{P}{EI}}\right)$$

A little consideration will show that either B is equal to zero or $\sin\left(l \sqrt{\frac{P}{EI}}\right) = 0$. Now if we consider B equal to zero, then it indicates that the column has not bent at all. But

if $\sin\left(l \sqrt{\frac{P}{EI}}\right) = 0$

$\therefore \left(l \sqrt{\frac{P}{EI}}\right) = 0 = \pi = 2\pi = 3\pi = \dots\dots\dots$

Now taking the least significant value,

$$\left(l \sqrt{\frac{P}{EI}} \right) = \pi$$

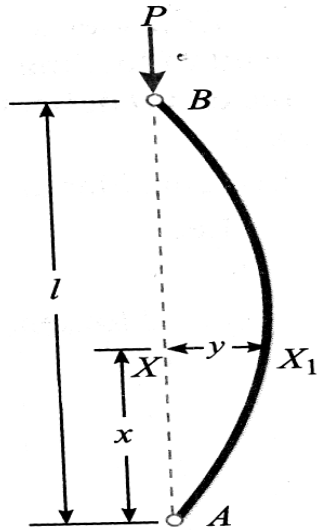

Or
$$p = \frac{\pi^2 EI}{l^2}$$

Columns with One End Fixed and the Other Free:-

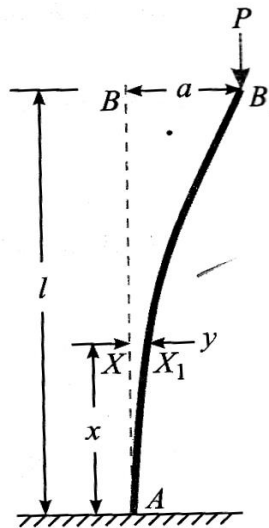

$$P = \frac{\pi^2 EI}{4l^2}$$

Columns with Both Ends Fixed:-

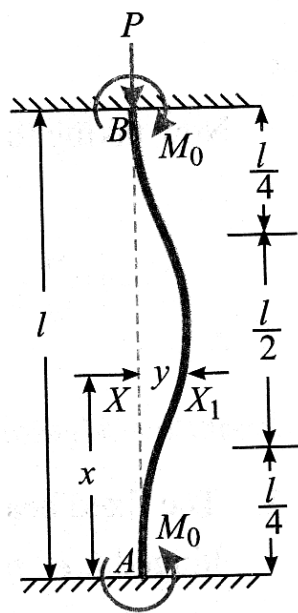

$$p = \frac{4\pi^2 EI}{l^2}$$

Columns with One End Fixed and the Other Hinged:-

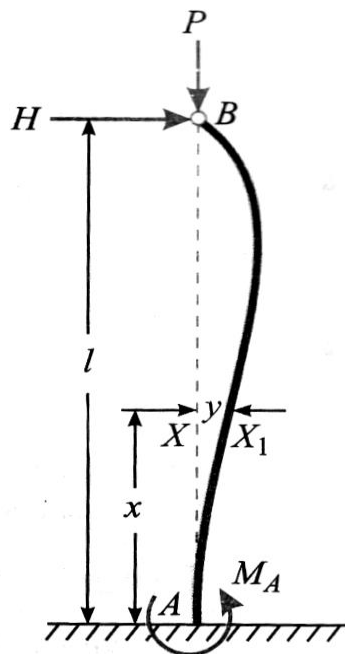

$$p = \frac{2\pi^2 EI}{l^2}$$

Equivalent length/Effective length of a column

The equivalent length of a given column with given end conditions, is the length of an equivalent column of the same material and cross-section with both ends hinged and having the value of the crippling load equal to that of the given column.

EXAMPLE 1:- A steel rod 5 m long and of 40 mm diameter is used as a column, with one end fixed and the other free. Determine the crippling load by Euler's formula. Take E as 200 GPa.

SOLUTION. Given:- Length (l) = 5×10^3 mm ; Diameter of column (d) = 40 mm and modulus of elasticity (E) = 200 GPa = 200×10^3 N/mm².

We know that moment of inertia of the column section,

$$I = \frac{\pi}{64} \times (d)^4 = \frac{\pi}{64} \times (40)^4 = 40000\pi \text{ mm}^4$$

Since the column is fixed at one end and free at the other, therefore equivalent length of the column,

$$L_e = 2l = 2 \times (5 \times 10^3) = 10 \times 10^3 \text{ mm}$$

$$\therefore \text{Euler's crippling load, } P_E = \frac{\pi^2 EI}{L_e^2} = \frac{\pi^2 \times (200 \times 10^3) \times (40000\pi)}{(10 \times 10^3)^2} = 2480 \text{ N}$$

$$= 2.48 \text{ kN}$$

Ans.

EXAMPLE 2:- A hollow alloy tube 4 m long external and internal diameters of 40 mm and 25 mm respectively was found to extend 4.8 mm under a tensile load of 60 kN. Find the buckling load for the tube with both ends pinned. Also find the safe load on the tube, taking a factor of safety as 5.

SOLUTION Given:- Length l , = 4 m ; External diameter of column (D) = 40 mm ; Internal diameter of column (d) = 25 mm; Deflection (δl) = 4.8 mm ; Tensile load = 60 kN = 60×10^3 N and factor of safety = 5.

Buckling load for the tube

We know that area of the tube,

$$A = \frac{\pi}{4} \times [D^2 - d^2] = \frac{\pi}{4} [(40)^2 - (25)^2] = 765.8 \text{ mm}^2$$

And moment of inertia of the tube,

$$I = \frac{\pi}{64} \times [D^4 - d^4] = \frac{\pi}{64} [(40)^4 - (25)^4] = 106\,500 \text{ mm}^4$$

We also know that strain in the alloy tube,

$$e = \frac{\delta l}{l} = \frac{4.8}{4 \times 10^3} = 0.0012$$

And modulus of elasticity for the alloy,

$$E = \frac{\text{Load}}{\text{Area} \times \text{Strain}} = \frac{60 \times 10^3}{765.8 \times 0.0012} = 65\,290 \text{ N/mm}^2$$

Since the column is pinned at its both ends, therefore equivalent length of the column,

$$L_e = l = 4 \times 10^3 \text{ mm}$$

$$\therefore \text{ Euler's buckling load, } P_E = \frac{\pi^2 EI}{L_e^2} = \frac{\pi^2 \times 65290 \times 106500}{(4 \times 10^3)^2} = 4290 \text{ N}$$

$$= 4.29 \text{ kN} \quad \text{Ans.}$$

Safe load for the tube

We also know that safe load for the tube

$$= \frac{\text{Bucklingload}}{\text{Factorofsafety}} = \frac{4.29}{5} = 0.858 \text{ kN} \quad \text{Ans.}$$

EXAMPLE 3:- Compare the ratio of the strength of a solid steel column to that of a hollow of the same cross-sectional area. The internal diameter of the hollow column is $\frac{3}{4}$ of the external diameter. Both the columns have the same length and are pinned at both ends.

SOLUTION. Given:- Area of solid steel column $A_S = A_H$ (where $A_H =$ Area of hollow column); internal diameter of hollow column (d) is $\frac{3D}{4}$ (where $D =$ External diameter) and length of solid column (l_s) = l_H (where $l_H =$ Length of hollow column).

- Let
- D_1 = Diameter of the solid column,
 - k_H = Radius of gyration for hollow column and
 - k_S = Radius of gyration for solid column.

Since both the columns are pinned at their both ends, therefore equivalent lengths of the solid column and hollow column,

$$L_S = l_S = L_H = l_H = L$$

We know that Euler's crippling load for the solid column,

$$P_s = \frac{\pi^2 EI}{L_s^2} = \frac{\pi^2 E \cdot A_s \cdot k_s^2}{L^2}$$

Similarly Euler's crippling load for the hollow column

$$P_H = \frac{\pi^2 EI}{L_H^2} = \frac{\pi^2 E \cdot A_H \cdot k_H^2}{L^2}$$

Dividing equation (ii) by (i),

$$\frac{P_H}{P_S} = \left(\frac{k_H}{k_S} \right)^2 = \frac{D^2 + d^2}{\frac{16}{D_1^2}} = \frac{D^2 + d^2}{D_1^2} = \frac{D^2}{D_1^2} = \left(\frac{3D}{4} \right)^2$$

$$= \frac{25D^2}{16D_1^2}$$

Since the cross-sectional areas of the columns is equal, therefore

$$\frac{\pi}{4} \times D_1^2 = \frac{\pi}{4} (D^2 - d^2) = \frac{\pi}{4} \left[D^2 - \left(\frac{3D}{4} \right)^2 \right] = \frac{\pi}{4} \times \frac{7D^2}{16}$$

$$\therefore D_1^2 = \frac{7D^2}{16}$$

Now substituting the value of D_1^2 in equation (iii),

$$\frac{P_H}{P_S} = \frac{25D^2}{16 \times \frac{7D^2}{16}} = \frac{25}{7}$$

Ans.

EXAMPLE 4:- An I section joist 400 mm x 200 mm x 20 mm and 6 m long is used as a strut with both ends fixed. What is Euler's crippling load for the column? Take Young's modulus for the joist as 200 GPa.

SOLUTION. Given:- Outer depth (D) = 400 mm ; Outer width (B) = 200 mm ; Length (l) = 6 m = 6 x 10³ mm and modulus of elasticity (E) = 200 GPa = 200 x 10³ N/mm² .

From the geometry of the figure, we find that inner depth,

$$d = 400 - (2 \times 20) = 360 \text{ mm}$$

and inner width, $b = 200 - 20 = 180 \text{ mm}$

We know that moment of inertia of the joist section about X-X is:

$$\begin{aligned} I_{XX} &= \frac{1}{12} [BD^3 - ba^3] \\ &= \frac{1}{12} [200 \times (400)^3 - 180 \times (360)^3] \text{ mm}^4 \\ &= 366.8 \times 10^6 \text{ mm}^4 \quad \dots(i) \end{aligned}$$

$$\begin{aligned} \text{Similarly } I_{YY} &= \left[2 \times \frac{2 \times (200)^3}{12} \right] + \frac{360 \times (20)^3}{12} \text{ mm}^4 \\ &= 2.91 \times 10^6 \text{ mm}^4 \end{aligned}$$

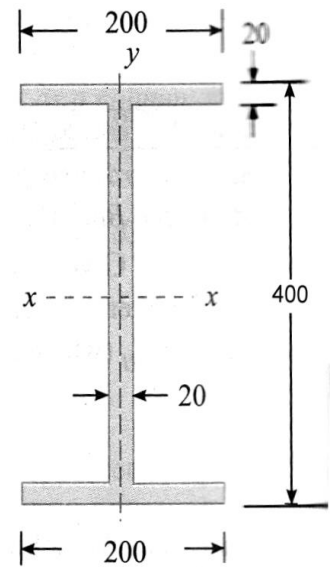

Since I_{YY} is less than I_{XX} , therefore the joist will tend to buckle in Y-Y direction.

Thus, we shall take the value of l as $I_{YY} = 2.91 \times 10^6 \text{ mm}^4$. Moreover, as the column is fixed at its both ends, therefore equivalent length of the column,

$$L_e = \frac{l}{2} = \frac{(6 \times 10^3)}{2} = 3 \times 10^3 \text{ mm}$$

∴ Euler's crippling load for the column,

$$\begin{aligned} P_E &= \frac{\pi^2 EI}{L_e^2} = \frac{\pi^2 \times (200 \times 10^3) \times (2.91 \times 10^6)}{(3 \times 10^3)^2} = 638.2 \times 10^3 \text{ N} \\ &= 638.2 \text{ kN} \quad \text{Ans.} \end{aligned}$$

CHAPTER-7

ARCHES

An arch may be defined as a curved girder, having convexity upwards, and supported at its ends. It may be subjected to vertical, horizontal or even inclined loads. In the past, the arches had been the backbone of the important buildings. But in the modern building activity, the arches are becoming obsolete. Today, the arches are being provided only for the architectural beauty in ultra modern buildings.

Types of arches:

A three-hinged arch may be either of the following two types, depending upon the geometry of its axis:

1. Parabolic arch
2. Circular arch

Practical application:

Actual arch:

Keeping all these factors, as well as the architectural beauty of an arch in view, its centre line is usually given a circular, parabolic or elliptical shape.

The supports A and B of the arch are called springing. The centre line of the arch (shown by chain line) is called axis of the arch. The highest point on the arch axis C is called crown of the arch and its height from the springing (y) is called rise of the arch as shown in fig.

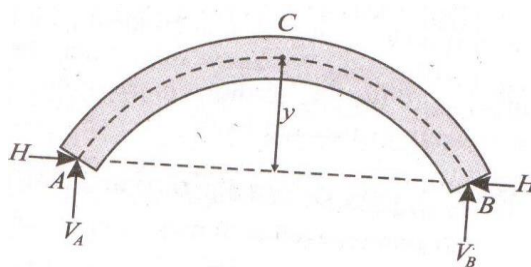

Three-hinged Parabolic Arch :

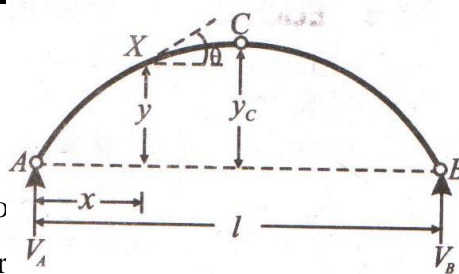

A three-hinged arch, who arch. Consider a three-hinged par

three-hinged parabolic ne supports A and B as

well as at the crown C, as shown in fig. Now consider a point X, on the axis of the arch, at a distance x from A.

Let Θ = Angle, which the tangent at X makes with the horizontal.

l = span AB of the arch

y = rise of the point X from the springings

y_c = rise of the crown from the springings

Now we taking A as the origin, we know that, equation for the centre line of a parabolic arch is,

$$y = k \times x(l - x) \text{-----(i)}$$

Where k is a constant.

We know that, when $x = \frac{l}{2}$, $y = y_c$. Therefore substituting these values of x and y in

the equation (i), we get

$$y_c = k \frac{l}{2} \left(l - \frac{l}{2} \right) = \frac{kl^2}{4}$$

$$k = \frac{4y_c}{l^2}$$

Now, substituting the value of k in equation (i), we get,

$$y = \frac{4y_c}{l^2} x(l - x) \text{-----(ii)}$$

This is the required equation for the rise y of an arch axis, from its springings, at a distance x from the support A or B

Note: 1. The value of y, when $x = \frac{l}{4}$

$$y = \frac{4y_c}{l^2} \frac{l}{4} \left(l - \frac{l}{4} \right) = \frac{3y_c}{4}$$

2. The slope of the angle Θ may be found out by differentiating the equation (ii) with respect to x i.e,

$$y = \frac{4y_c}{l^2} x(l - x) = \frac{4y_c}{l^2} (lx - x^2)$$

$$\frac{dy}{dx} = \tan \theta = \frac{4y_c}{l^2} (l - 2x)$$

Horizontal Thrust in a Three-hinged Arch:

The arches, having hinged supports, at their two ends and also having a third hinge, anywhere between the two ends, are known as three-hinged arches. The third hinge is, usually, placed at the crown of the arch. Since no bending moment can exist at the hinges, therefore the line of thrust, in a three-hinged arch, must pass through the three hinges. The reactions at the two have both vertical and horizontal components when an arch is subjected to vertical loads only. The horizontal components at the two supports will be equal and opposite. When the two ends of an arch are at the same level, the two vertical reaction R_A and R_B may be found out in the same way as in a simply supported beam.

Let l = span of the arch

y_c = Central rise of the arch

H = Horizontal thrust on the arch.

A little consideration will show that, bending moment at the crown of the arch,

$$M_c = \mu_c - Hy_c$$

μ_c = Beam moment at C due to loading (i.e by considering the arch as a simply supported beam of span l)

Hy_c = Moment due to horizontal thrust.

Since the arch is hinged at its crown, therefore the bending moment at the crown C will be zero.

$$\mu_c - Hy_c = 0$$

$$Hy_c = \mu_c$$

$$H = \frac{\mu_c}{y_c}$$

This is the required equation for the horizontal thrust on an arch.

Example 7.1: A three-hinged parabolic arch of span 40m and rise 10m is carrying a uniformly distributed load as shown in fig: Find the horizontal thrust at the springings.

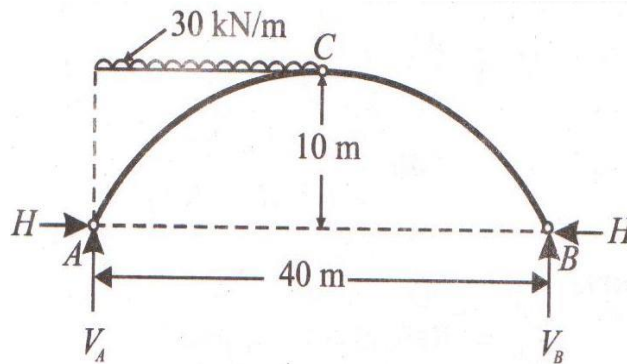

Solution : Given: Span (l) = 40m and central rise (y_c) = 10 m

H = Horizontal thrust at the springings.

V_A = Vertical reaction at A , and

V_B = Vertical reaction at B

Vertical reaction V_B at B can be calculated by taking moments about A and equating anticlockwise moments with clockwise moments.

$$V_B \times 40 = (30 \times 20) \times 10 = 6000$$

$$V_B = \frac{6000}{40} = 150 \text{ kN}$$

The beam moment at C due to external loading,

$$\mu_c = V_B \times 20 = 150 \times 20 = 3000 \text{ kN-m}$$

$$\text{Horizontal thrust, } H = \frac{\mu_c}{y_c} = \frac{3000}{10} = 300 \text{ kN}$$

Example7.2: A Three-hinged parabolic arch of span 20m and central rise of 5 m carries a point load of 200kN at 6m from the left hand support as shown in fig:

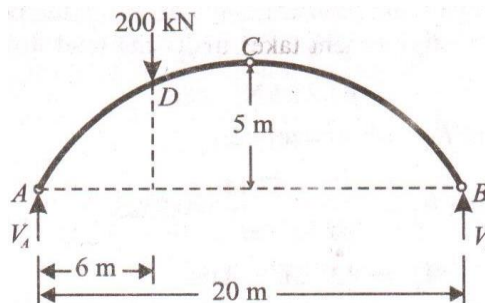

- Find the reaction at the supports A and B.
- Draw the bending moment diagram for the arch, and indicate the position of maximum bending moment.

Solution: Given: Span(l) = 20m, Central rise (y_c) = 5m and horizontal distance between the load and the left support (x) = 6m

Reaction at the supports

Let V_A = Vertical reaction at A

V_B = Vertical reaction at B

Vertical reaction V_B at B can be calculated by taking moments about A and equating anticlockwise and clockwise moments,

$$V_B \times 20 = 200 \times 6 = 1200$$

$$V_B = \frac{1200}{20} = 60 \text{ kN}$$

$$V_A = 200 - 60 = 140 \text{ kN}$$

The beam moment at C, due to external loading,

$$\mu_c = V_B \times 10 = 60 \times 10 = 600 \text{ kN-m}$$

Horizontal thrust at A and B, $H = \frac{\mu_c}{y_c} = \frac{600}{5} = 120 \text{ kN}$

We know that Reaction at A,

$$R_A = \sqrt{V_A^2 + H^2} = \sqrt{140^2 + 120^2} = \sqrt{3400} \\ = 184.4 \text{ kN}$$

And Reaction at B,

$$R_B = \sqrt{V_B^2 + H^2} = \sqrt{60^2 + 120^2} = \sqrt{18000} \\ = 134.2 \text{ kN}$$

Position of maximum bending moment

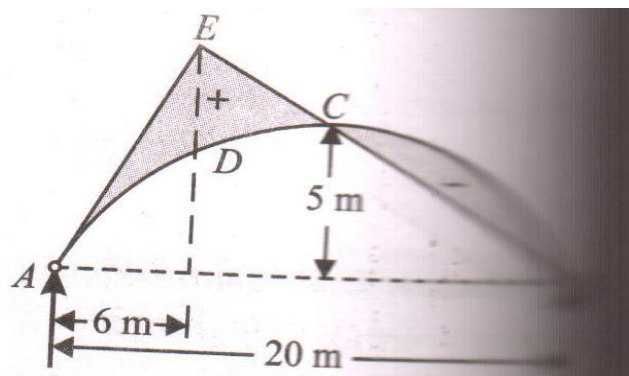

First of all draw the bending moment diagram as discussed below:

1. Draw the arch ACB with the given span and rise.
2. Since the bending moment at A, B and C is zero, therefore join B and extend this line.
3. Draw a vertical line through D, meeting the line BC at E.
4. Join AE.

Now, AEB is the required bending moment diagram. From the bending moment diagram, we see the maximum positive bending moment takes under the load.

Rise of the arch at D,

$$y = \frac{4y_c}{l^2} x(l-x)$$

$$= \frac{4 \times 5}{20^2} \times 6(20-6) = \frac{6 \times 14}{20} = 4.2m$$

Maximum positive bending moment at D

$$M_{\max} = (V_A \times 6) - (H \times 4.2) = (140 \times 6) - (120 \times 4.2)$$

$$= 840 - 504 = 336kN - m$$

From the bending moment diagram, we also see that the maximum negative bending moment takes place in the section CB. Let the maximum negative bending moment take place at a distance of x from B. We know that, Rise of arch at a distance x from B.

$$y = \frac{4y_c}{l^2} x(l-x) = \frac{4 \times 5}{20 \times 20} x(20-x)$$

$$= \frac{x}{20} (20-x) = x - \frac{x^2}{20}$$

Bending moment at X at a distance x from B,

$$M_x = V_B x - Hy = 60x - 120 \left(x - \frac{x^2}{20} \right)$$

$$= 60x - 120x + 6x^2$$

$$= 6x^2 - 60x$$

Now, for max. Bending moment, let us differentiate the above equation w.r.to x and equate it to zero

$$\frac{d}{dx} (6x^2 - 60x) = 0$$

$$12x - 60 = 0$$

$$x = 5m$$

Rise of the arch at a distance of 5m from B,

$$* y = \frac{4y_c}{l^2} x(l-x) = \frac{4 \times 5}{20 \times 20} \times 5(20-5)$$

$$= \frac{5 \times 15}{20} = \frac{15}{4} m$$

Max. Negative bending moment at a distance of 5m from B.

$$M_{\max} = V_B x - Hy = (60 \times 5) - \left(120 \times \frac{15}{4} \right)$$

$$= -150kN - m$$

Note: We can also calculate the rise of arch at a distance of $l/4$ from C

$$y = \frac{3y_c}{4} = \frac{3 \times 5}{4} = \frac{15}{4} m$$